

LSP945S3-6

Powered by Perkins®

- 60HZ
- Water-cooled
- Three Phase
- Diesel

Model		LSP945S3-6
Standby Power	KVA	945
	KW	755.2
Prime Power	KVA	850
	KW	680
Frequency	Hz	60
Voltage	V	208/416
Rated speed	rpm	1800

Perkins is one of the largest engine manufacturer in the world with more than 4000 business outlets, providing power to 5000 different applications with advanced technology.

Lees Perkins range of generator sets provide reliable power solutions for every business, every need. Prime power or standby service, diesel fuel generator sets deliver dependable, clean, economic power, even in the most demanding conditions – and are available in a wide range of configurations with optional equipment.

Perkins engine → Model: 4006-23TAG3A



Main features:

- The 400 series engine family continues to set new standards in the compact engine market. Developed alongside customers to fulfill their needs in the genset, compressor, agricultural and general industrial markets.
- These new ElectropaKs provide compact power, from a robust family of 3 and 4 cylinder diesel engines designed to provide economic and durable operation at Prime and Standby duties, hitting the key power nodes requires by the power generation industry.
- Long-term Power Solution
The 400 range of ElectropaKs has been designed to fully comply with stringent EU and EPA emissions regulations, providing an emissions compliant power solution for the future.
- Cost effective power
 - Compact size and low noise
 - Lower fuel consumption and oil use
 - 500 hours service intervals
 - 2 year warranty



Engine specifications:

Air inlet

- Mounted air filter

Fuel system

- Mechanically governed cassette type fuel injection pump
- Split element fuel filter

Lubrication system

- Wet steel sump with filler and dipstick
- Spin-on full-flow lub oil filter

Cooling system

- Thermostat controlled system with belt driven coolant pump and pusher fan
- Mounted radiator, piping and guards

Electrical equipment

- 12V starter motor and 12V 65A alternator with DC output
- Glow plug cold start aid and heater/starter switch
- 12V shut down solenoid – energized to run cold start aid
- Oil pressure and coolant temperature switches

Flywheel and housing

- High inertia flywheel to SAE J620 size 7 1/2 Heavy flywheel housing SAE 4 Long

Mountings

- Front and rear engine mounting brackets

Perkins engine → Model: 4006-23TAG3A

General data	
Cylinder No.	6
Cylinder arrangement	Vertical in-line
Cycle	4 stroke
Induction system	Turbocharged and air-to-air charge cooled
Combustion system	Direct injection
Cooling system	Water-cooled
Bore X Stroke (mm)	160X190
Displacement (L)	22.921
Compression ratio	13.6:1
Direction of rotation	Anti-clockwise, viewed on flywheel
Lubrication capacity (L)	113.4
Coolant capacity (L)	105
Dimension (LXWXH) (mm)	3027X1706X1964
Dry weight (kg)	2524

Fuel consumption		
Engine speed	1800 rev/min	
Fuel consumption	g/kwh	l/hr
Standby	/	203
Prime power	/	175
75% of prime power	/	132
50% of prime power	/	88

The above ratings represent the engine performance capabilities to conditions specified in ISO 8528/1, ISO 3046/1:1986, BS 5514/1

Prime power: power available at variable load with a load factor not exceeding 80% of the prime power rating. Overload of 10% permitted for 1 hour in every 12 hours' operation

Standby power: power available in the event of a main power network failure up to a maximum of 500 hours per year of which up to 300 hours may be run continuously. No overload is permitted

LEES alternator → Model: HCI634G
Main features:

- Self excited control or auxiliary winding to provide sustained short circuit capability
- Easy access for installation and maintenance
- 2/3 pitch winding as standard, to avoid excessive neutral currents
- Advance automatic voltage regulator (AVR) control
- Single or two bearing construction with dynamically balanced rotor and sealed-for-life bearings
- IP23 as standard

Alternator specifications

Control system	Separately excited by PMG
A.V.R.	MX321
Voltage regulation	±0.5%
Insulation system	Class H
Protection	IP23
Stator winding	Double layer lap
Winding pitch	2/3
Winding leads	6
Stator wdg. resistance	0.003 Ohms per phase at 22°C series star connected
Rotor wdg. resistance	1.75 Ohms at 22°C
Excited stator resistance	17 Ohms at 22°C
Excited rotor resistance	0.079 Ohms per phase at 22°C
Waveform distortion	No load <1.5% non-distorting balanced linear load <5.0%
Maximum overspeed	2250 Rev/Min
Bearing drive end	BALL.6224 (ISO)
Bearing non-drive end	BALL.6317 (ISO)
Packing crate size	183X92X140 (cm)
Telephone interference	THF <50 (60Hz)
Cooling air	1.961 m3/sec

Alternator options

Stamford	HCI634G
Leroy Somer	TAL A49 C
Lees	LA6B

Deepsea control module → Model: 7320



The DSE7320 is an Auto Mains (Utility) Failure Control Module suitable for a wide variety of single, diesel or gas, gen-set applications.

Monitoring an extensive number of engine parameters, the modules will display warnings, shutdown and engine status information on the back-lit LCD screen, illuminated LEDs, remote PC and via SMS text alerts (with external modem).

The DSE7320 will also monitor the mains (utility) supply. The modules include USB, RS232 and RS485 ports as well as dedicated DSENet terminals for system expansion.



Key Features:

- 4-line back-lit LCD text display
- Five key menu navigation
- Front panel editing with PIN protection
- LED and LCD alarm indication
- Customisable status screens
- Power save mode
- Support for up to three remote display units
- 9 configurable inputs
- 8 configurable outputs
- Flexible sender inputs
- Configurable timers and alarms
- 3 configurable maintenance alarms
- Multiple date and time scheduler
- Configurable event log (250)
- Control logic facilities
- Easy access diagnostic page
- CAN and Magnetic Pick-up / Alt. Sensing
- Fuel usage monitor and low fuel alarms
- Charger alternator failure alarm
- Manual speed control
- Manual fuel pump control
- Engine exerciser
- “Protectons disabled” feature
- kW overload protection
- Power monitoring
- Load switching (load shedding and dummy load outputs)
- Automatic load transfer
- Unbalanced load protection
- Independent Earth Fault trip
- USB connectivity
- Backed up real time clock
- Fully configurable via DSE Configurable Suite PC software
- Configurable display languages
- Remote SCADA monitoring via DSE Configuration Suite PC software
- User selectable RS232 and RS485 communications
- SMS Messaging (additiional external modem required)
- Additional display screens to help with modem diagnostics
- DSENet expansion compatible
- Integral PLC editor

Deepsea control module → Model: 7320

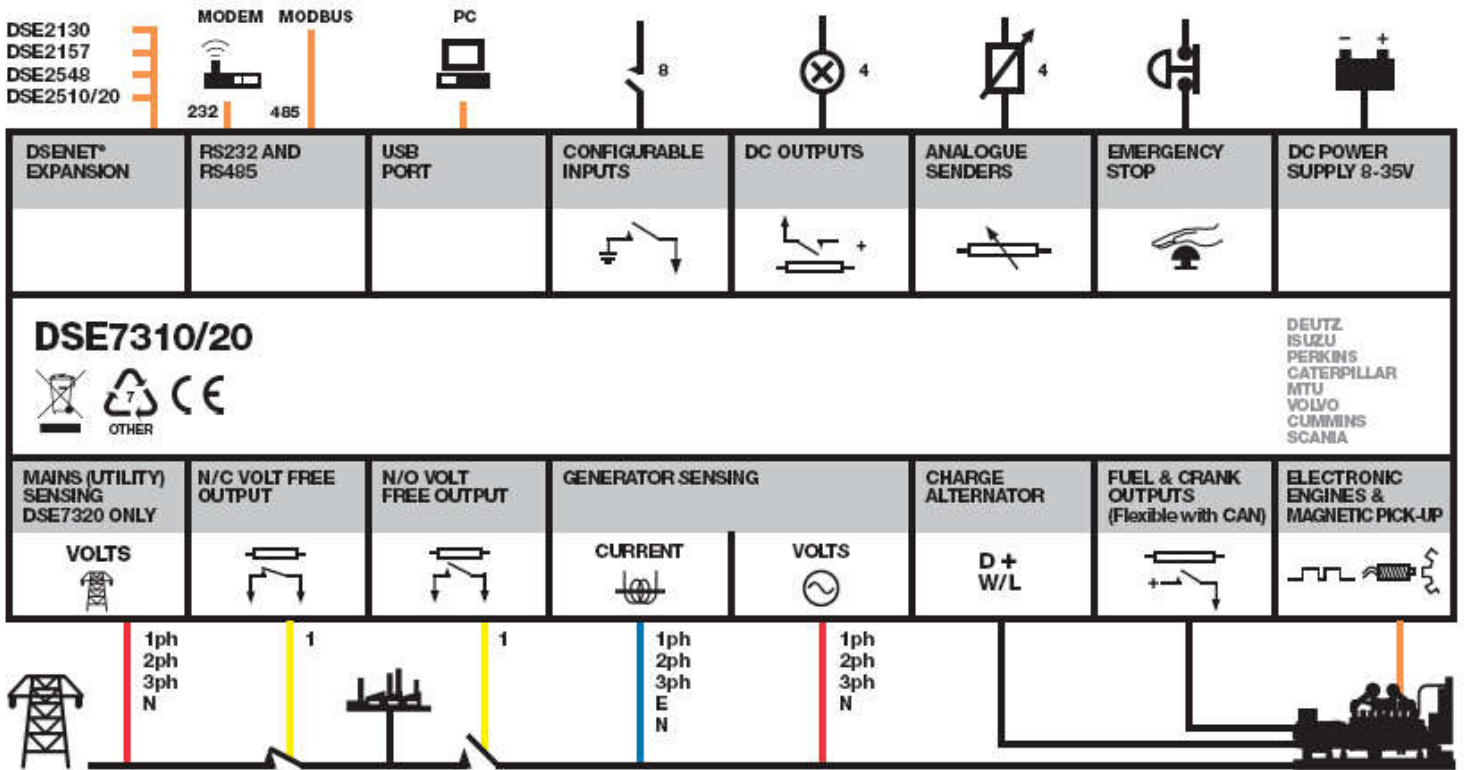

Overview dimension & Sound levels

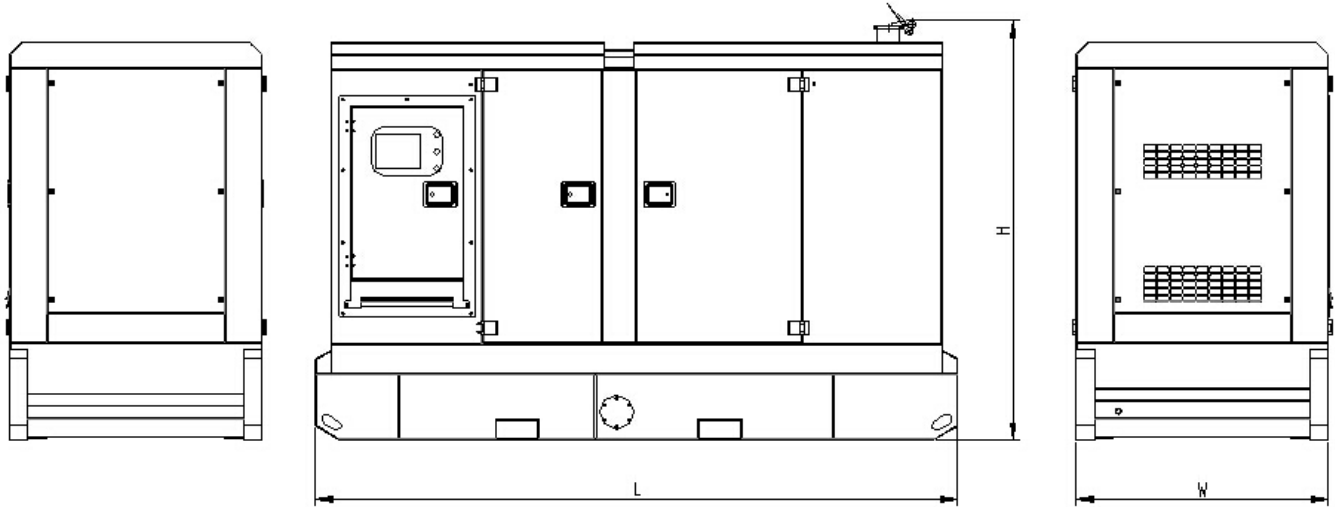

LSP945S3-6 (Silent type)

Configuration	L= Length (mm)	W= Width (mm)	H= High (mm)	Weight (kg)
Enclosed set	5806	2260	2554	7880

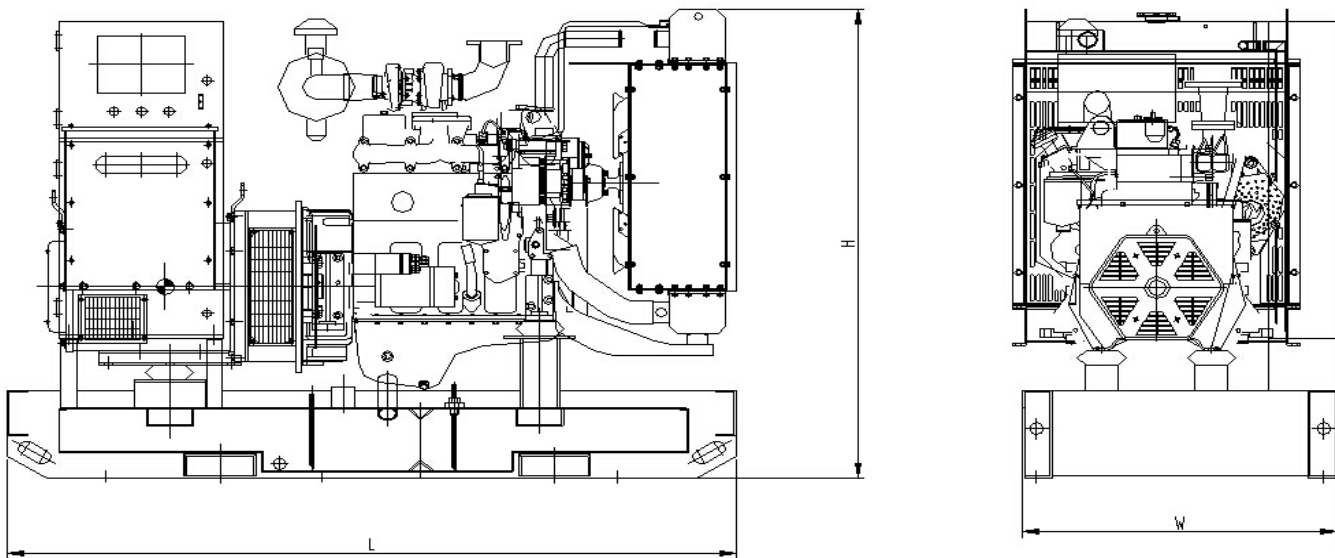

LSP945E3-6 (Open type)

Configuration	L= Length (mm)	W= Width (mm)	H= High (mm)	Weight (kg)
Open set	4700	1780	2400	5740

Generating Sets Standard and Optional Features

Engine:

- 4-stroke, water-cooled diesel engine
- Standard air filter
- Standard fuel filter
- Standard oil filter
- Oil temperature sensor
- Low coolant level sensor
- 24V electrical system
- Radiator with blowing fan
- Industrial silence
- **Fuel water separator (optional)**
- **Water jacket heater (optional)**

Alternator:

- Class H insulation
- IP23 Protection
- Automatic Voltage Regulator (AVR)
- PMG excitation
- Single bearing alternator
- Lees alternator
- **Stamford alternator (optional)**

Electrical system:

- DSE 7320 control module
- Maintenance-free and anti-explosion battery
- Standard breaker
- **ABB breaker (optional)**
- **ATS (optional)**

- **Battery charger (optional)**
- **GMS monitoring (optional)**

Packing:

- Engine manual
- Alternator manual
- Gensets operation and maintenance manual
- Tool kit

Baseframe:

- Forklift pockets
- Pulling slots
- Earth wire protection
- Built-in anti vibration mountings
- Fuel outlet valve
- Standard 8 hours fuel tank
- **Enlarged 24 hours fuel tank (optional)**
- **Separated fuel tank (optional)**

Canopy:

- Weatherproof & sound-attenuated canopy
- Sound-absorbing material
- Lifting lug
- Emergency stop button
- Inside silencer
- **Trailer (optional)**

Contact your distributor / dealer for more information

WUXI LEES POWER COMPANY LIMITED

NO.312 Highway, Luoshe Town, Wuxi, China, 214000

Tel: 86-510-85166446

Fax: 86-510-85168446

Web: www.leespowers.com

Email: lees@leespowers.com

