

## LSP72S3

Powered by Perkins®

- 50HZ
- Water-cooled
- Three Phase
- Diesel

Model	LSP72S3	
Standby Power	KVA	72
	KW	57
Prime Power	KVA	65
	KW	52
Frequency	Hz	50
Voltage	V	230/400
Rated speed	rpm	1500

Perkins is one of the largest engine manufacturer in the world with more than 4000 business outlets, providing power to 5000 different applications with advanced technology.

Lees Perkins range of generator sets provide reliable power solutions for every business, every need. Prime power or standby service, diesel fuel generator sets deliver dependable, clean, economic power, even in the most demanding conditions – and are available in a wide range of configurations with optional equipment.

**Perkins engine → Model: 1104A-44TG1**



**Main features:**

- Compact and efficient power
  - 1100 series is the result of an intensive period of customer research that has guided the development of the range
  - The new 3.3 L cylinder block ensures bore roundness is maintained under the pressures of operation. It also ensures combustion and mechanical noise is lowered
  - A new cylinder head has re-established Perkins mastery of air control
- Quality by design
  - Product design and Class A manufacturing improvements enhance product reliability while maintaining Perkins legendary reputation for durability
- Cost effective power
  - Compact size and low noise
  - Lower fuel consumption and oil use
  - 500 hours service intervals
  - 2 year warranty



**Engine specifications:**

**Air inlet**

- Mounted air filter

**Fuel system**

- Rotary fuel injection pump
- Ecoplus fuel filter

**Lubrication system**

- Wet steel sump with filler and dipstick
- Spin-on oil filter

**Cooling system**

- Thermostat controlled cooling system with gear driven water pump and belt-driven pusher fan
- Mounted radiator and piping incorporating air-to-air

charger cooler

**Electrical equipment**

- 12V starter motor and 12V 65A alternator with DC output
- Glow plug cold start aid
- 12V shut down solenoid – energized to run cold start aid

**Flywheel and housing**

- High inertia flywheel to SAE J620 size 10/11 1/2
- SAE 3 flywheel housing

**Mountings**

- Front engine mounting bracket

**Perkins engine → Model: 1104A-44TG1**

General data	
Cylinder No.	4
Cylinder arrangement	Vertical in-line
Cycle	4 stroke
Induction system	Turbocharged
Combustion system	Direct injection
Cooling system	Water-cooled
Bore X Stroke (mm)	105X127
Displacement (L)	4.4
Compression ratio	17.25:1
Direction of rotation	Anti-clockwise, viewed on flywheel
Lubrication capacity (L)	8.0
Coolant capacity (L)	13.0
Dimension (LXWXH) (mm)	1241X629X951
Dry weight (kg)	463

Fuel consumption		
Engine speed	1500 rev/min	
Fuel consumption	UK g/hr	l/hr
Standby	3.2	14.8
Prime power	2.4	11.2
75% of prime power	1.7	8.0
50% of prime power	1.0	4.6

The above ratings represent the engine performance capabilities to conditions specified in ISO 8528/1, ISO 3046/1:1986, BS 5514/1

Prime power: power available at variable load with a load factor not exceeding 80% of the prime power rating. Overload of 10% permitted for 1 hour in every 12 hours' operation

Standby power: power available in the event of a main power network failure up to a maximum of 500 hours per year of which up to 300 hours may be run continuously. No overload is permitted

## Alternator

Main features:

- 12 wire reconnectable stator/terminal arrangement
- Easy access for installation and maintenance
- 2/3 pitch winding as standard, to avoid excessive neutral currents
- Class H insulation with severe environmental protection as standard
- Built to conform with all leading industrial and marine standards
- 460 AVR as standard with 1.5% regulation and 2 phase sensing
- IP23 as standard

### Alternator specifications

<b>Control system</b>	Self excited
<b>A.V.R.</b>	SX460
<b>Voltage regulation</b>	±1.0%
<b>Insulation system</b>	Class H
<b>Protection</b>	IP23
<b>Stator winding</b>	Double layer concentric
<b>Winding pitch</b>	2/3
<b>Winding leads</b>	12
<b>Stator wdg. resistance</b>	0.065Ohms per phase at 22°C series star connected
<b>Rotor wdg. resistance</b>	0.83 Ohms at 22°C
<b>Excited stator resistance</b>	20 Ohms at 22°C
<b>Excited rotor resistance</b>	0.078 Ohms per phase at 22°C
<b>Waveform distortion</b>	No load <1.5% non-distorting balanced linear load <5.0%
<b>Maximum overspeed</b>	2250 Rev/Min
<b>Bearing drive end</b>	BALL.6312-2RS.(ISO)
<b>Bearing non-drive end</b>	BALL.6306-2RS.(ISO)
<b>Packing crate size</b>	105X57X96 (cm)
<b>Telephone interference</b>	THF<50
<b>Cooling air</b>	0.216m3/sec 458 cfm

### Alternator options

<b>Stamford</b>	UCI 224F
<b>Leroy Somer</b>	TAL-A44-C
<b>Lees</b>	LA 224F

**Deepsea control module → Model: 6020**

The DSE6020 is an Auto Mains (Utility) Failure Control Module suitable for a wide variety of single, diesel or gas, gen-set applications.

Monitoring an extensive number of engine parameters, the modules will display warnings, shutdown and engine status information on the back-lit LCD screen, illuminated LEDs, remote PC and via SMS test alerts (with external modem).

The DSE6020 will also monitor the mains (utility) supply. The modules include USB, RS232 and RS485 ports as well as dedicated DSENet terminals for system expansion.

**Key Features:**

- 4-line back-lit LCD text display
- Five key menu navigation
- Front panel editing with PIN protection
- LED and LCD alarm indication
- Customisable status screens
- Power save mode
- Support for up to three remote display units
- 9 configurable inputs
- 8 configurable outputs
- Flexible sender inputs
- Configurable timers and alarms
- 3 configurable maintenance alarms
- Multiple date and time scheduler
- Configurable event log (250)
- Control logic facilities
- Easy access diagnostic page
- CAN and Magnetic Pick-up / Alt. Sensing
- Fuel usage monitor and low fuel alarms
- Charger alternator failure alarm
- Manual speed control
- Manual fuel pump control
- Engine exerciser
- "Protections disabled" feature
- kW overload protection
- Power monitoring
- Load switching (load shedding and dummy load outputs)
- Automatic load transfer
- Unbalanced load protection
- Independent Earth Fault trip
- USB connectivity
- Backed up real time clock
- Fully configurable via DSE Configurable Suite PC software
- Configurable display languages
- Remote SCADA monitoring via DSE Configuration Suite PC software
- User selectable RS232 and RS485 communications
- SMS Messaging (additional external modem required)
- Additional display screens to help with modem diagnostics
- DSENet expansion compatible
- Integral PLC editor

**Overview dimension & Sound levels**

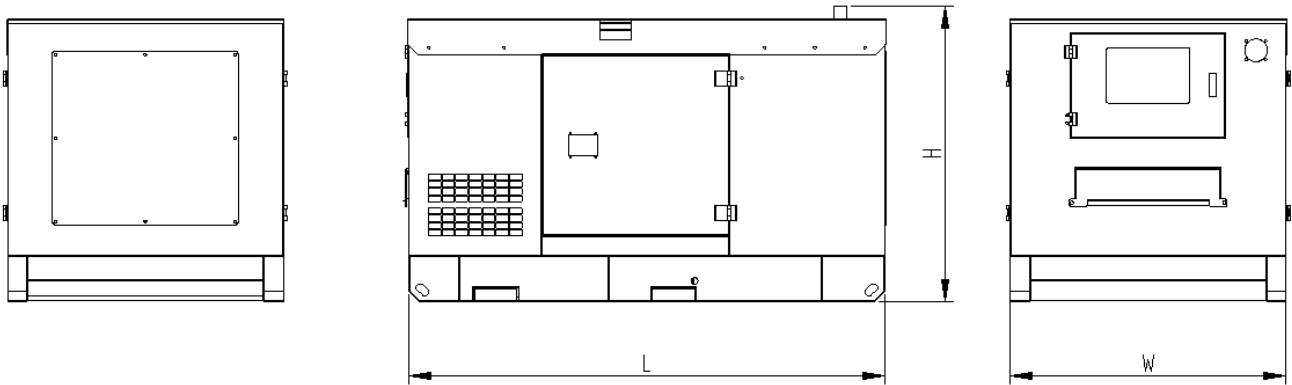

**LSP72S3 (Silent type)**

Configuration	L= Length (mm)	W= Width (mm)	H= Height (mm)	Weight(kg)
Enclosed set	2452	955	1450	1290

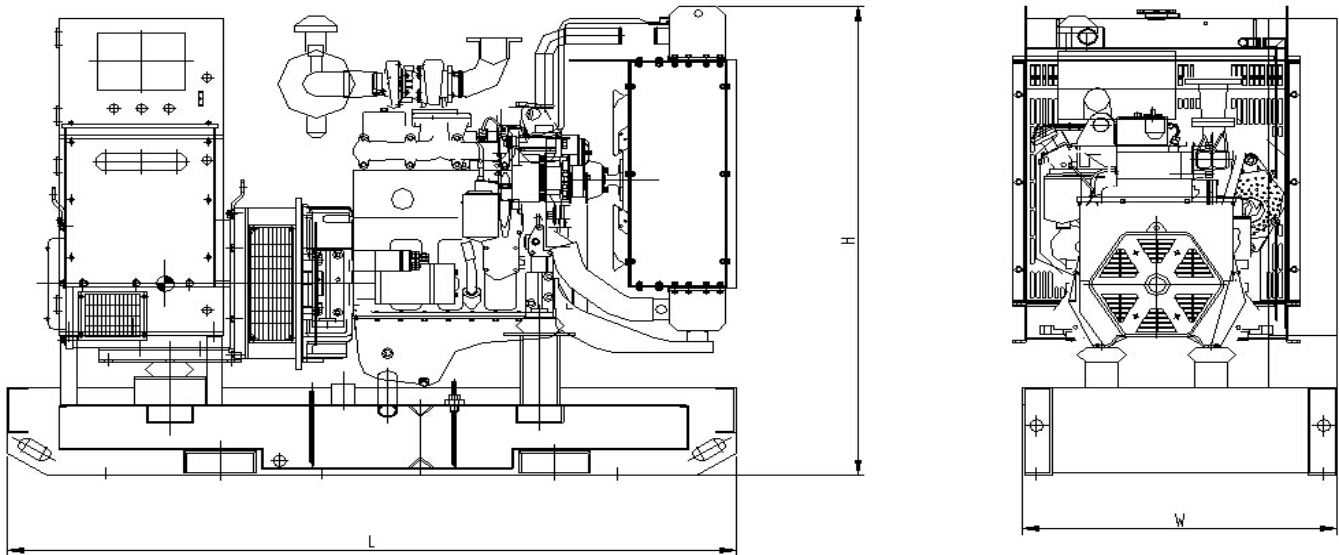

**LSP72E3 (Open type)**

Configuration	L= Length (mm)	W= Width (mm)	H= Height (mm)	Weight(kg)
Open set	1760	760	1380	970

## Generating Sets Standard and Optional Features

### Engine:

- 4-stroke, water-cooled diesel engine
- Standard air filter
- Standard fuel filter
- Standard oil filter
- Oil temperature sensor
- Low coolant level sensor
- 24V electrical system
- Radiator with blowing fan
- Industrial silence
- **Fuel water separator (optional)**
- **Water jacket heater (optional)**

### Alternator:

- Class H insulation
- IP23 Protection
- Automatic Voltage Regulator (AVR)
- PMG excitation
- Single bearing alternator
- Lees alternator
- **Stamford alternator (optional)**

### Electrical system:

- DSE 6020 control module
- Maintenance-free and anti-explosion battery
- Standard breaker
- **ABB breaker (optional)**
- **ATS (optional)**

- **Battery charger (optional)**
- **GMS monitoring (optional)**

### Packing:

- Engine manual
- Alternator manual
- Gensets operation and maintenance manual
- Tool kit

### Baseframe:

- Forklift pockets
- Pulling slots
- Earth wire protection
- Built-in anti vibration mountings
- Fuel outlet valve
- Standard 8 hours fuel tank
- **Enlarged 24 hours fuel tank (optional)**
- **Separated fuel tank (optional)**

### Canopy:

- Weatherproof & sound-attenuated canopy
- Sound-absorbing material
- Lifting lug
- Emergency stop button
- Inside silencer
- **Trailer (optional)**

## Contact your distributor / dealer for more information

### WUXI LEES POWER COMPANY LIMITED

NO.312 Highway, Luoshe Town, Wuxi, China, 214000

Tel: 86-510-85166446

Fax: 86-510-85168446

Web: [www.leespowers.com](http://www.leespowers.com)

Email: [lees@leespowers.com](mailto:lees@leespowers.com)

