



## LSP550S3

Powered by  Perkins®

-  50HZ
-  Water-cooled
-  Three Phase
-  Diesel

Model		LSP550S3
Standby Power	KVA	550
	KW	440
Prime Power	KVA	500
	KW	400
Frequency	Hz	50
Voltage	V	230/400
Rated speed	rpm	1500

Perkins is one of the largest engine manufacturer in the world with more than 4000 business outlets, providing power to 5000 different applications with advanced technology.

Lees Perkins range of generator sets provide reliable power solutions for every business, every need. Prime power or standby service, diesel fuel generator sets deliver dependable, clean, economic power, even in the most demanding conditions – and are available in a wide range of configurations with optional equipment.

**Perkins engine → Model: 2506C-E15TAG2**



**Main features:**

- Economic power
  - Mechanically operated unit fuel injectors with advanced electronic control, combined with carefully matched turbocharging, give excellent fuel atomization which leads to exceptional low fuel consumption
- Reliable power
  - Developed and tested using the latest engineering techniques and finite element analysis for high reliability
  - Low oil usage and low wear rates
  - High compression ratio ensures clean rapid starting in all conditions
  - Support comes from a worldwide network of 4,000 distributors and dealers
- Compact, clean and efficient power
  - Exceptional power to weight ratio and compact size gives optimum power density for ease of installation and more cost effective transportation
  - Designed to provide excellent service access for ease of maintenance
- Cost effective power
  - Compact size and low noise
  - Lower fuel consumption and oil use
  - 500 hours service intervals
  - 2 year warranty



**Engine specifications:**

**Air inlet**

- Mounted air filter

**Fuel system**

- Mechanically actuated electronically controlled unit fuel injectors with full authority electronic control
- Governing to ISO 8528-5 class G2 with isochronous capability
- Replaceable 'Ecoplus' fuel filter elements with primary filter/water separator
- Fuel cooler

**Lubrication system**

- Wet sump with filter and dipstick
- Full-flow replaceable 'Ecoplus' filter
- Oil cooler integral with filter header

**Cooling system**

- Gear-driven circulating pump
- Mounted belt-driven fan
- Radiator supplied loose incorporating air-to-air charger cooler
- System designed for ambient up to 50 °C

**Electrical equipment**

- 24V starter motor and 24V 70A alternator with DC output
- ECM mounted on engine with wiring looms and sensors
- 3 level engine protection system

**Perkins engine → Model: 2506C-E15TAG2**
**General data**

<b>Cylinder No.</b>	6
<b>Cylinder arrangement</b>	Vertical in-line
<b>Cycle</b>	4 stroke
<b>Induction system</b>	Turbocharged and air-to-air charge cooled
<b>Combustion system</b>	Direct injection
<b>Cooling system</b>	Water-cooled
<b>Bore X Stroke (mm)</b>	137X171
<b>Displacement (L)</b>	15.2
<b>Compression ratio</b>	16:1
<b>Direction of rotation</b>	Anti-clockwise, viewed on flywheel
<b>Lubrication capacity (L)</b>	62
<b>Coolant capacity (L)</b>	58
<b>Dimension (LXWXH) (mm)</b>	2657X1120X1718
<b>Dry weight (kg)</b>	1633

**Fuel consumption**

<b>Engine speed</b>	1500 rev/min	
<b>Fuel consumption</b>	g/kwh	l/hr
<b>Standby</b>	207	115
<b>Prime power</b>	211	106
<b>75% of prime power</b>	215	81
<b>50% of prime power</b>	220	55

The above ratings represent the engine performance capabilities to conditions specified in ISO 8528/1, ISO 3046/1:1986, BS 5514/1

Prime power: power available at variable load with a load factor not exceeding 80% of the prime power rating. Overload of 10% permitted for 1 hour in every 12 hours' operation

Standby power: power available in the event of a main power network failure up to a maximum of 500 hours per year of which up to 300 hours may be run continuously. No overload is permitted

## Alternator

Main features:

- 12 wire reconnectable stator/terminal arrangement
- Easy access for installation and maintenance
- 2/3 pitch winding as standard, to avoid excessive neutral currents
- Class H insulation with severe environmental protection as standard
- Built to conform with all leading industrial and marine standards
- 460 AVR as standard with 1.5% regulation and 2 phase sensing
- IP23 as standard

### Alternator specifications

<b>Control system</b>	Self excited
<b>A.V.R.</b>	AS440
<b>Voltage regulation</b>	±1.0%
<b>Insulation system</b>	Class H
<b>Protection</b>	IP23
<b>Stator winding</b>	Double layer lap
<b>Winding pitch</b>	2/3
<b>Winding leads</b>	12
<b>Stator wdg. resistance</b>	0.0065 Ohms per phase at 22°C series star connected
<b>Rotor wdg. resistance</b>	1.77 Ohms at 22°C
<b>Excited stator resistance</b>	17 Ohms at 22°C
<b>Excited rotor resistance</b>	0.092 Ohms per phase at 22°C
<b>Waveform distortion</b>	No load <1.5% non-distorting balanced linear load <5.0%
<b>Maximum overspeed</b>	2250 Rev/Min
<b>Bearing drive end</b>	BALL.6220 (ISO)
<b>Bearing non-drive end</b>	BALL.6314 (ISO)
<b>Packing crate size</b>	166X87X124 (cm)
<b>Telephone interference</b>	THF <2% (50Hz)
<b>Cooling air</b>	1.035m3/sec 2202 cfm

### Alternator options

<b>Stamford</b>	S5L1D-D4
<b>Leroy Somer</b>	TAL047D
<b>Lees</b>	LA 5D

## Deepsea control module → Model: 7320

The DSE7320 is an Auto Mains (Utility) Failure Control Module suitable for a wide variety of single, diesel or gas, gen-set applications.

Monitoring an extensive number of engine parameters, the modules will display warnings, shutdown and engine status information on the back-lit LCD screen, illuminated LEDs, remote PC and via SMS text alerts (with external modem).

The DSE7320 will also monitor the mains (utility) supply. The modules include USB, RS232 and RS485 ports as well as dedicated DSENet terminals for system expansion.



### Key Features:

- 4-line back-lit LCD text display
- Five key menu navigation
- Front panel editing with PIN protection
- LED and LCD alarm indication
- Customisable status screens
- Power save mode
- Support for up to three remote display units
- 9 configurable inputs
- 8 configurable outputs
- Flexible sender inputs
- Configurable timers and alarms
- 3 configurable maintenance alarms
- Multiple date and time scheduler
- Configurable event log (250)
- Control logic facilities
- Easy access diagnostic page
- CAN and Magnetic Pick-up / Alt. Sensing
- Fuel usage monitor and low fuel alarms
- Charger alternator failure alarm
- Manual speed control
- Manual fuel pump control
- Engine exerciser
- “Protections disabled” feature
- kW overload protection
- Power monitoring
- Load switching (load shedding and dummy load outputs)
- Automatic load transfer
- Unbalanced load protection
- Independent Earth Fault trip
- USB connectivity
- Backed up real time clock
- Fully configurable via DSE Configurable Suite PC software
- Configurable display languages
- Remote SCADA monitoring via DSE Configuration Suite PC software
- User selectable RS232 and RS485 communications
- SMS Messaging (additional external modem required)
- Additional display screens to help with modem diagnostics
- DSENet expansion compatible
- Integral PLC editor

Deepsea control module → Model: 7320

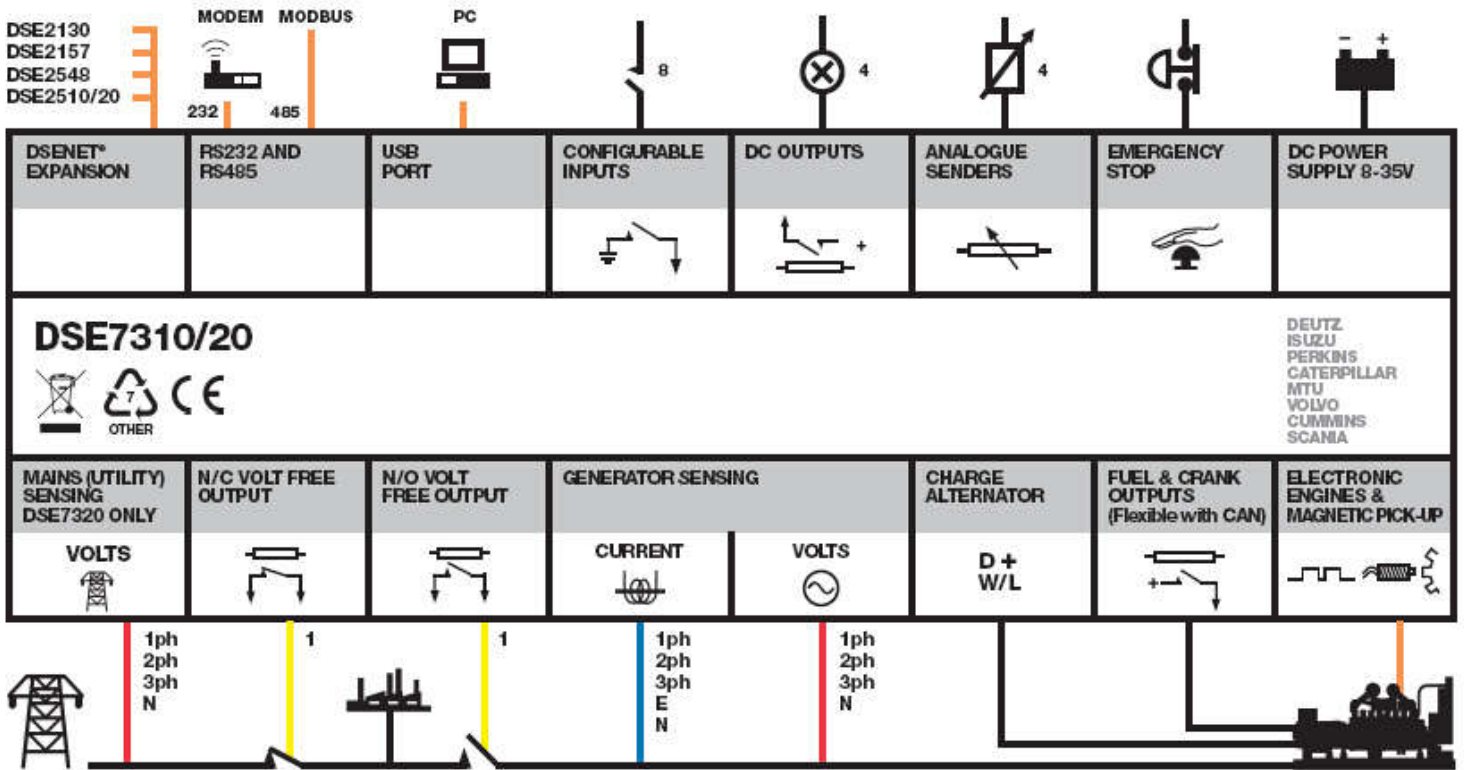

**Overview dimension & Sound levels**

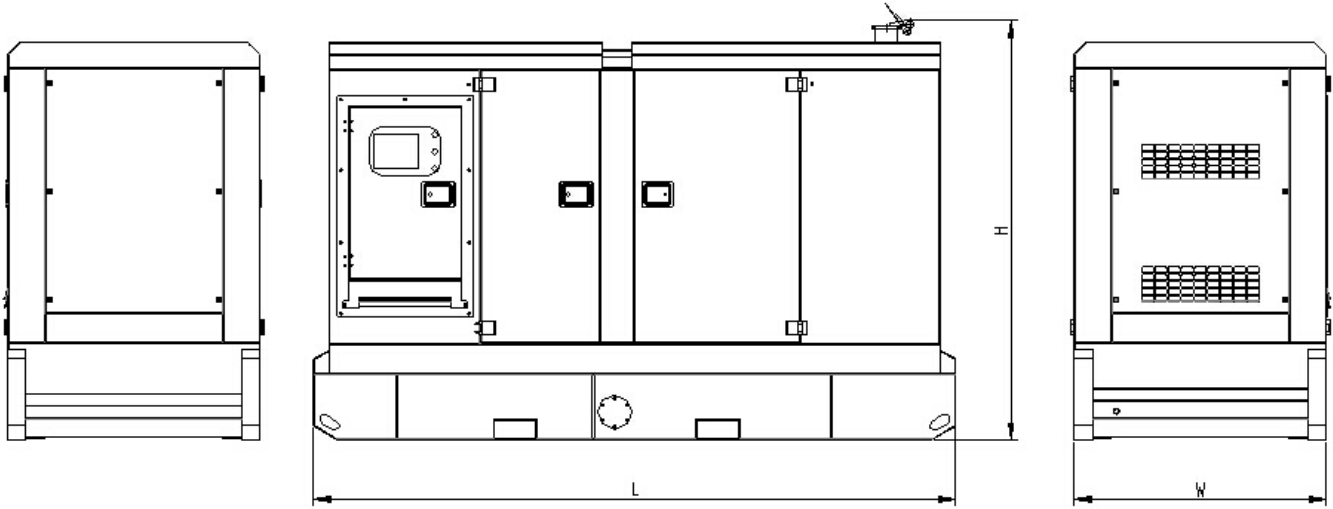

**LSP550S3 (Silent type)**

Configuration	L= Length (mm)	W= Width (mm)	H= Height (mm)	Weight(kg)
Enclosed set	4700	1630	2350	4895

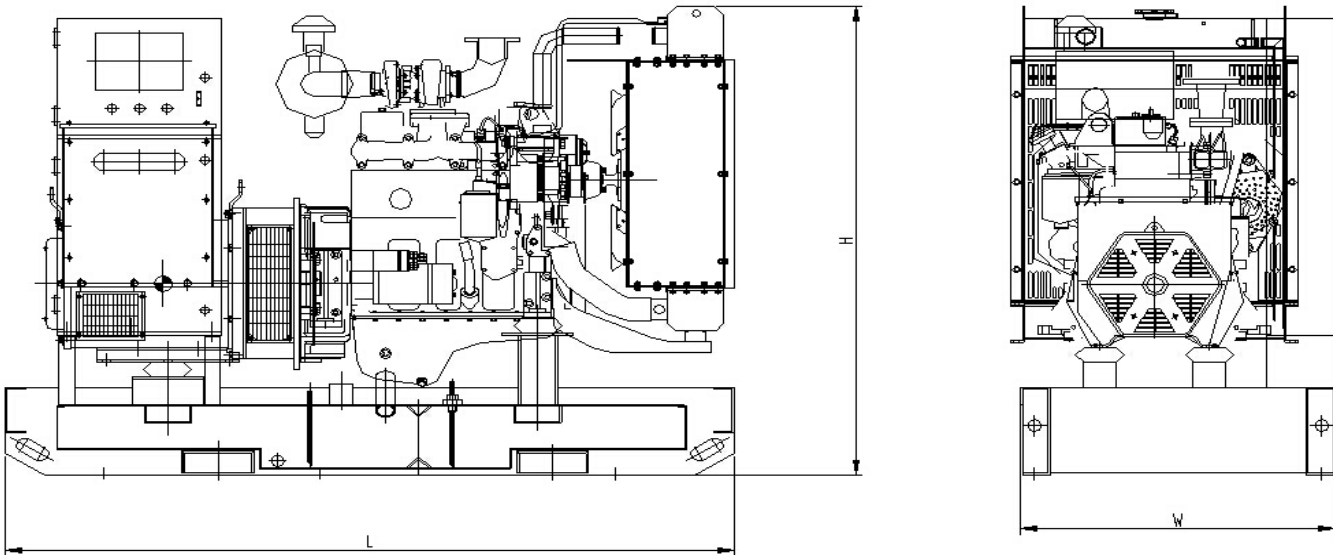

**LSP550E3 (Open type)**

Configuration	L= Length (mm)	W= Width (mm)	H= Height (mm)	Weight(kg)
Open set	3600	1400	2100	3900

## Generating Sets Standard and Optional Features

### Engine:

- 4-stroke, water-cooled diesel engine
- Standard air filter
- Standard fuel filter
- Standard oil filter
- Oil temperature sensor
- Low coolant level sensor
- 24V electrical system
- Radiator with blowing fan
- Industrial silence
- **Fuel water separator (optional)**
- **Water jacket heater (optional)**

### Alternator:

- Class H insulation
- IP23 Protection
- Automatic Voltage Regulator (AVR)
- PMG excitation
- Single bearing alternator
- Lees alternator
- **Stamford alternator (optional)**

### Electrical system:

- DSE 7320 control module
- Maintenance-free and anti-explosion battery
- Standard breaker
- **ABB breaker (optional)**
- **ATS (optional)**

- **Battery charger (optional)**
- **GMS monitoring (optional)**

### Packing:

- Engine manual
- Alternator manual
- Gensets operation and maintenance manual
- Tool kit

### Baseframe:

- Forklift pockets
- Pulling slots
- Earth wire protection
- Built-in anti vibration mountings
- Fuel outlet valve
- Standard 8 hours fuel tank
- **Enlarged 24 hours fuel tank (optional)**
- **Separated fuel tank (optional)**

### Canopy:

- Weatherproof & sound-attenuated canopy
- Sound-absorbing material
- Lifting lug
- Emergency stop button
- Inside silencer
- **Trailer (optional)**

## Contact your distributor / dealer for more information

### WUXI LEES POWER COMPANY LIMITED

NO.312 Highway, Luoshe Town, Wuxi, China, 214000

Tel: 86-510-85166446

Fax: 86-510-85168446

Web: [www.leespower.com](http://www.leespower.com)

Email: [lees@leespower.com](mailto:lees@leespower.com)

