



LSP250S3-1

Powered by Perkins®

- 50HZ
- Water-cooled
- Three Phase
- Diesel

Model		LSP250S3-1
Standby Power	KVA	250
	KW	200
Prime Power	KVA	230
	KW	184
Frequency	Hz	50
Voltage	V	230/400
Rated speed	rpm	1500

Perkins is one of the largest engine manufacturer in the world with more than 4000 business outlets, providing power to 5000 different applications with advanced technology.

Lees Perkins range of generator sets provide reliable power solutions for every business, every need. Prime power or standby service, diesel fuel generator sets deliver dependable, clean, economic power, even in the most demanding conditions – and are available in a wide range of configurations with optional equipment.

Perkins engine → Model: 1206A-E70TTAG2



Main features:

- Lower operating costs
 - The 1500 Series is designed to provide low cost of ownership, simple maintenance and reduced downtime. Oil change intervals are set at 500 hours as standard. One of its most impressive benefits is a fuel saving of up to seven percent on previous models. This is significant in terms of reducing ownership and operating costs. In fact, five to seven years of fuel savings at this level will pay for the entire cost of the engine.
- Performance you can rely on
 - 1500 Series has world-class power density that is achieved using a hydraulic actuated unit injection (HEUI) fuel system. This makes the engine robust enough for any territory as it can cope with the variation in fuel quality around the world. The engines are also designed to provide reliable power even in the most extreme climates and performed above and beyond expectations in ambient testing. It also has an improved capability of up to eight percent at altitude making it a durable and dependable performer.
- Cost effective power
 - Compact size and low noise
 - Lower fuel consumption and oil use
 - 500 hours service intervals
 - 2 year warranty



Engine specifications:

Air inlet

- Mounted air filter

Fuel system

- Mechanically actuated electronically controlled unit fuel injectors with full authority electronic control
- Governing to ISO 8528-5 class G2 with isochronous capability
- Replaceable 'Ecoplus' fuel filter elements with primary filter/water separator
- Fuel cooler

Lubrication system

- Wet sump with filter and dipstick
- Full-flow replaceable 'Ecoplus' filter
- Oil cooler integral with filter header

Cooling system

- Gear-driven circulating pump
- Mounted belt-driven fan
- Radiator supplied loose incorporating air-to-air charger cooler
- System designed for ambient up to 50 °C

Electrical equipment

- 24V starter motor and 24V 70A alternator with DC output
- ECM mounted on engine with wiring looms and sensors
- 3 level engine protection system

Perkins engine → Model: 1206A-E70TTAG2

General data	
Cylinder No.	6
Cylinder arrangement	Vertical, In-line
Cycle	4 stroke
Induction system	TTA
Compression ratio	15.8:1
Bore X Stroke (mm)	105X135
Displacement (L)	7.01
Dry weight (kg)	797
Wet weight (kg)	832
Dimension (LXWXH) (mm)	1426X1878X949

Fuel consumption		
Engine speed	1500 rev/min	
Fuel consumption	g/kwh	l/hr
110% of prime power	211.7	56.6
100% of prime power	209.7	51.0
75% of prime power	208.2	38.0
50% of prime power	209.6	25.5
25% of prime power	231.1	14.0

The above ratings represent the engine performance capabilities to conditions specified in ISO 8528/1, ISO 3046/1:1986, BS 5514/1

Prime power: power available at variable load with a load factor not exceeding 80% of the prime power rating. Overload of 10% permitted for 1 hour in every 12 hours' operation

Standby power: power available in the event of a main power network failure up to a maximum of 500 hours per year of which up to 300 hours may be run continuously. No overload is permitted

Alternator

Main features:

- 12 wire reconnectable stator/terminal arrangement
- Easy access for installation and maintenance
- 2/3 pitch winding as standard, to avoid excessive neutral currents
- Class H insulation with severe environmental protection as standard
- Built to conform with all leading industrial and marine standards
- 460 AVR as standard with 1.5% regulation and 2 phase sensing
- IP23 as standard

Alternator specifications

Control system	Self excited
A.V.R.	SX460
Voltage regulation	±1.0%
Insulation system	Class H
Protection	IP23
Stator winding	Double layer lap
Winding pitch	2/3
Winding leads	12
Stator wdg. resistance	0.0126 Ohms per phase at 22°C series star connected
Rotor wdg. resistance	2.08 Ohms at 22°C
Excited stator resistance	20 Ohms at 22°C
Excited rotor resistance	0.091 Ohms per phase at 22°C
Waveform distortion	No load <1.5% non-distorting balanced linear load <5.0%
Maximum overspeed	2250 Rev/Min
Bearing drive end	/
Bearing non-drive end	BALL.6310-2RS (ISO)
Packing crate size	123X67X103 (cm)
Telephone interference	THF <2% (50Hz)
Cooling air	0.58 m3/sec 1230 cfm

Alternator options

Stamford	UCDI274J
Leroy Somer	TAL046C
Lees	LA 274J

Deepsea control module → Model: 6020

The DSE6020 is an Auto Mains (Utility) Failure Control Module suitable for a wide variety of single, diesel or gas, gen-set applications.

Monitoring an extensive number of engine parameters, the modules will display warnings, shutdown and engine status information on the back-lit LCD screen, illuminated LEDs, remote PC and via SMS text alerts (with external modem).

The DSE6020 will also monitor the mains (utility) supply. The modules include USB, RS232 and RS485 ports as well as dedicated DSENet terminals for system expansion.



Key Features:

- 4-line back-lit LCD text display
- Five key menu navigation
- Front panel editing with PIN protection
- LED and LCD alarm indication
- Customisable status screens
- Power save mode
- Support for up to three remote display units
- 9 configurable inputs
- 8 configurable outputs
- Flexible sender inputs
- Configurable timers and alarms
- 3 configurable maintenance alarms
- Multiple date and time scheduler
- Configurable event log (250)
- Control logic facilities
- Easy access diagnostic page
- CAN and Magnetic Pick-up / Alt. Sensing
- Fuel usage monitor and low fuel alarms
- Charger alternator failure alarm
- Manual speed control
- Manual fuel pump control
- Engine exerciser
- "Protections disabled" feature
- kW overload protection
- Power monitoring
- Load switching (load shedding and dummy load outputs)
- Automatic load transfer
- Unbalanced load protection
- Independent Earth Fault trip
- USB connectivity
- Backed up real time clock
- Fully configurable via DSE Configurable Suite PC software
- Configurable display languages
- Remote SCADA monitoring via DSE Configuration Suite PC software
- User selectable RS232 and RS485 communications
- SMS Messaging (additional external modem required)
- Additional display screens to help with modem diagnostics
- DSENet expansion compatible
- Integral PLC editor

Overview dimension & Sound levels

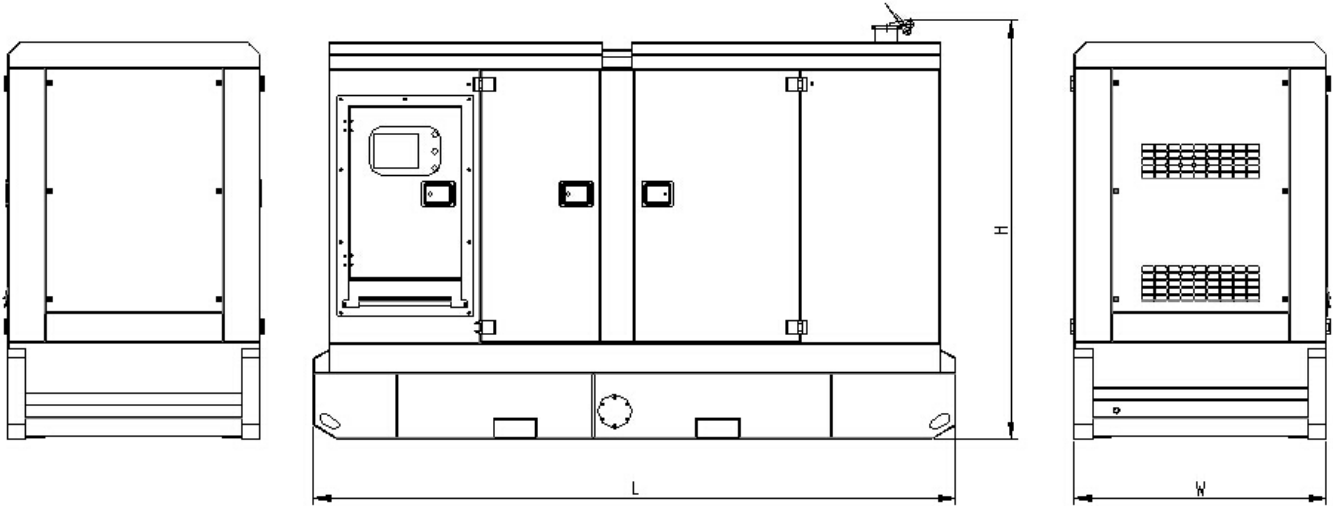

LSP250S3-1 (Silent type)

Configuration	L= Length (mm)	W= Width (mm)	H= Height (mm)	Weight(kg)
Enclosed set	3620	1232	2050	2780

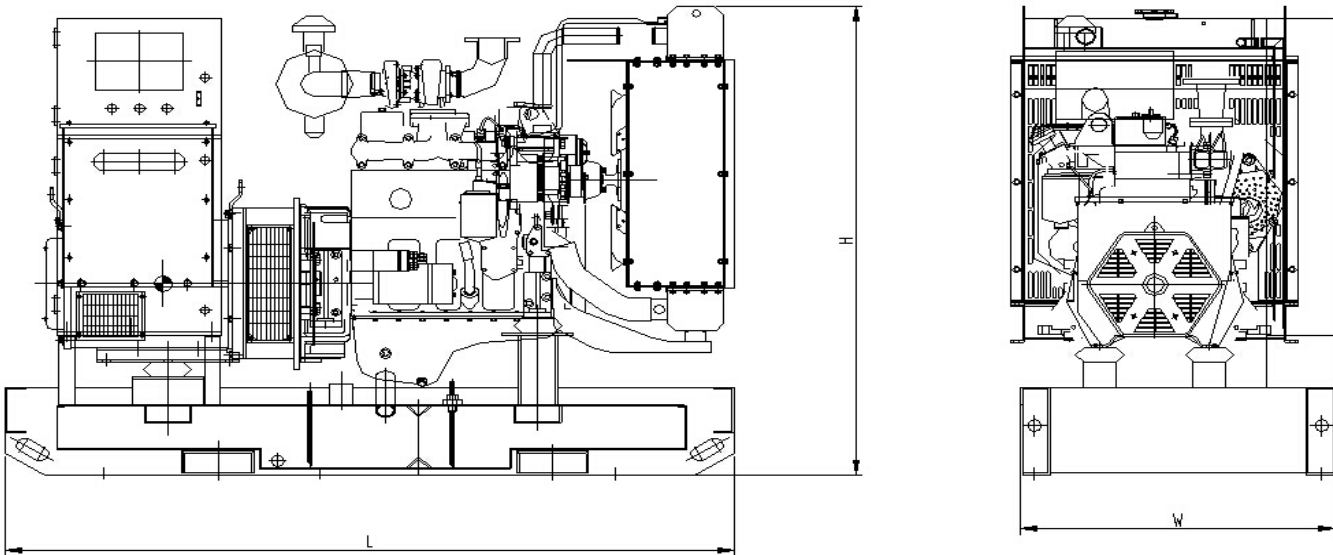

LSP250E3-1 (Open type)

Configuration	L= Length (mm)	W= Width (mm)	H= Height (mm)	Weight(kg)
Open set	2580	930	1670	2130

Generating Sets Standard and Optional Features

Engine:

- 4-stroke, water-cooled diesel engine
- Standard air filter
- Standard fuel filter
- Standard oil filter
- Oil temperature sensor
- Low coolant level sensor
- 24V electrical system
- Radiator with blowing fan
- Industrial silence
- **Fuel water separator (optional)**
- **Water jacket heater (optional)**

Alternator:

- Class H insulation
- IP23 Protection
- Automatic Voltage Regulator (AVR)
- PMG excitation
- Single bearing alternator
- Lees alternator
- **Stamford alternator (optional)**

Electrical system:

- DSE 6020 control module
- Maintenance-free and anti-explosion battery
- Standard breaker
- **ABB breaker (optional)**
- **ATS (optional)**

- **Battery charger (optional)**
- **GMS monitoring (optional)**

Packing:

- Engine manual
- Alternator manual
- Gensets operation and maintenance manual
- Tool kit

Baseframe:

- Forklift pockets
- Pulling slots
- Earth wire protection
- Built-in anti vibration mountings
- Fuel outlet valve
- Standard 8 hours fuel tank
- **Enlarged 24 hours fuel tank (optional)**
- **Separated fuel tank (optional)**

Canopy:

- Weatherproof & sound-attenuated canopy
- Sound-absorbing material
- Lifting lug
- Emergency stop button
- Inside silencer
- **Trailer (optional)**

Contact your distributor / dealer for more information

WUXI LEES POWER COMPANY LIMITED

NO.312 Highway, Luoshe Town, Wuxi, China, 214000

Tel: 86-510-85166446

Fax: 86-510-85168446

Web: www.leespower.com

Email: lees@leespower.com



