

LSM650E3

Prime Powered by MTU



- 50HZ
- Water-cooled
- Three Phase
- Diesel

Model	LSM650E3 (Primed powered by MTU)	
Prime Power	kVA	650
	kw	520
Frequency	Hz	50
Voltage	V	230/400
Rated speed	rpm	1500
Fuel Consumption 100% Load	g/kw.h	192
Fuel Consumption 75% Load	g/kw.h	197
Fuel Consumption 50% Load	g/kw.h	206

LEES MTU diesel generators have a wide power range from 650~3300kVA. The generators are built for the best quality, efficiency and environment protection. Favorable in high-end market, used as emergency power for power station, airport, skyscrapers, data center, jumbo factories and etc.

MTU Daimler - Benz Group of Companies, is the world's leading diesel engine manufacturer. LEES MTU diesel high-power generator sets, powered by MTU electronic injection diesel engine, which will get 24 hour engine technical, after sale, parts support from more than 650 MTU dealers and service agents around the globe.

MTU-C-3B engine → Model: 12V2000G25

MTU-C-3B Engine: 12V2000G25	
Air intake system	Turbo, Air/Air Cooling
Fuel system	Electronic Fuel Injection System
Cylinder arrangement	12 in V
Displacement	21L
BorexStroke	122x150mm
Compression ratio	17.5:1
Rated RPM	1500
Governor	ADEC
Exhaust gas flow	2100L/S
Exhaust temperature	483°C
Max. back pressure	15kPa
Max. intake restriction	5kPa
Burning capacity	800L/S
Total oil capacity	73L
Total coolant capacity	130L
Max. water temperature	105°C

Engine	Dimension (LxWxH) mm	Dry Weight (kg)
12V	1882x1580x1585	2490
16V	2226x1580x2015	3150
18V	2400x1780x2015	3500

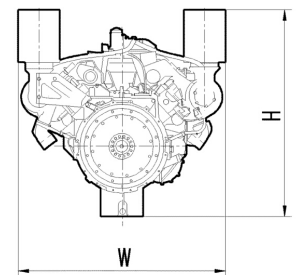
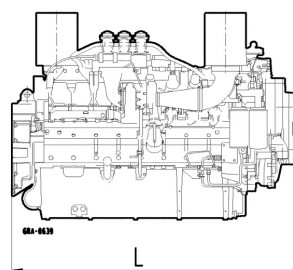

STAMFORD Alternator → Model: S5L1D-F4

Main features:

- 12 wire reconnectable stator/terminal arrangement
- Easy access for installation and maintenance
- 2/3 pitch winding as standard, to avoid excessive neutral currents
- Class H insulation with severe environmental protection as standard
- Built to conform with all leading industrial and marine standards
- 460 AVR as standard with 1.5% regulation and 2 phase sensing
- IP23 as standard

STAMFORD®

STAMFORD Alternator: S5L1D-F4	
Number of phase	3
Connecting type	3 Phase 4 Wire, "Y" type connecting
Number of bearing	1
Protection grade	IP23
Exciter type	Brushless, self-exciting
Insulation class, Temperature rise	H/H
Telephone Influence Factor (TIF)	<50
THF	<2%
Voltage Regulation, Steady state	≤±1%
Alternator capacity	670kVA
Alternator efficiencies	95%
Air cooling flow	1.035m ³ /s

Deepsea control module → Model: 7320



The DSE7320 is an Auto Mains (Utility) Failure Control Module suitable for a wide variety of diesel or gas genset applications.

Monitoring an extensive number of engine parameters, the modules will display warnings, shutdown and engine status information on the back-lit LCD screen, illuminated LEDs, remote PC and via SMS test alerts (with external modem).

The DSE7320 will also monitor the mains (utility) supply. The modules include USB, RS232 and RS485 ports as well as dedicated DSENet terminals for system expansion.



Key Features:

- 4-line back-lit LCD text display
- Five key menu navigation
- Front panel editing with PIN protection
- LED and LCD alarm indication
- Customisable status screens
- Power save mode
- Support for up to three remote display units
- 9 configurable inputs
- 8 configurable outputs
- Flexible sender inputs
- Configurable timers and alarms
- 3 configurable maintenance alarms
- Multiple date and time scheduler
- Configurable event log (250)
- Control logic facilities
- Easy access diagnostic page
- CAN and Magnetic Pick-up / Alt. Sensing
- Fuel usage monitor and low fuel alarms
- Charger alternator failure alarm
- Manual speed control
- Manual fuel pump control
- Engine exerciser
- “Protectons disabled” feature
- kW overload protection
- Power monitoring
- Load switching (load shedding and dummy load outputs)
- Automatic load transfer
- Unbalanced load protection
- Independent Earth Fault trip
- USB connectivity
- Backed up real time clock
- Fully configurable via DSE Configurable Suite PC software
- Configurable display languages
- Remote SCADA monitoring via DSE Configuration Suite PC software
- User selectable RS232 and RS485 communications
- SMS Messaging (additiional external modem required)
- Additional display screens to help with modem diagnostics
- DSENet expansion compatible
- Integral PLC editor

Deepsea control module → Model: 7320

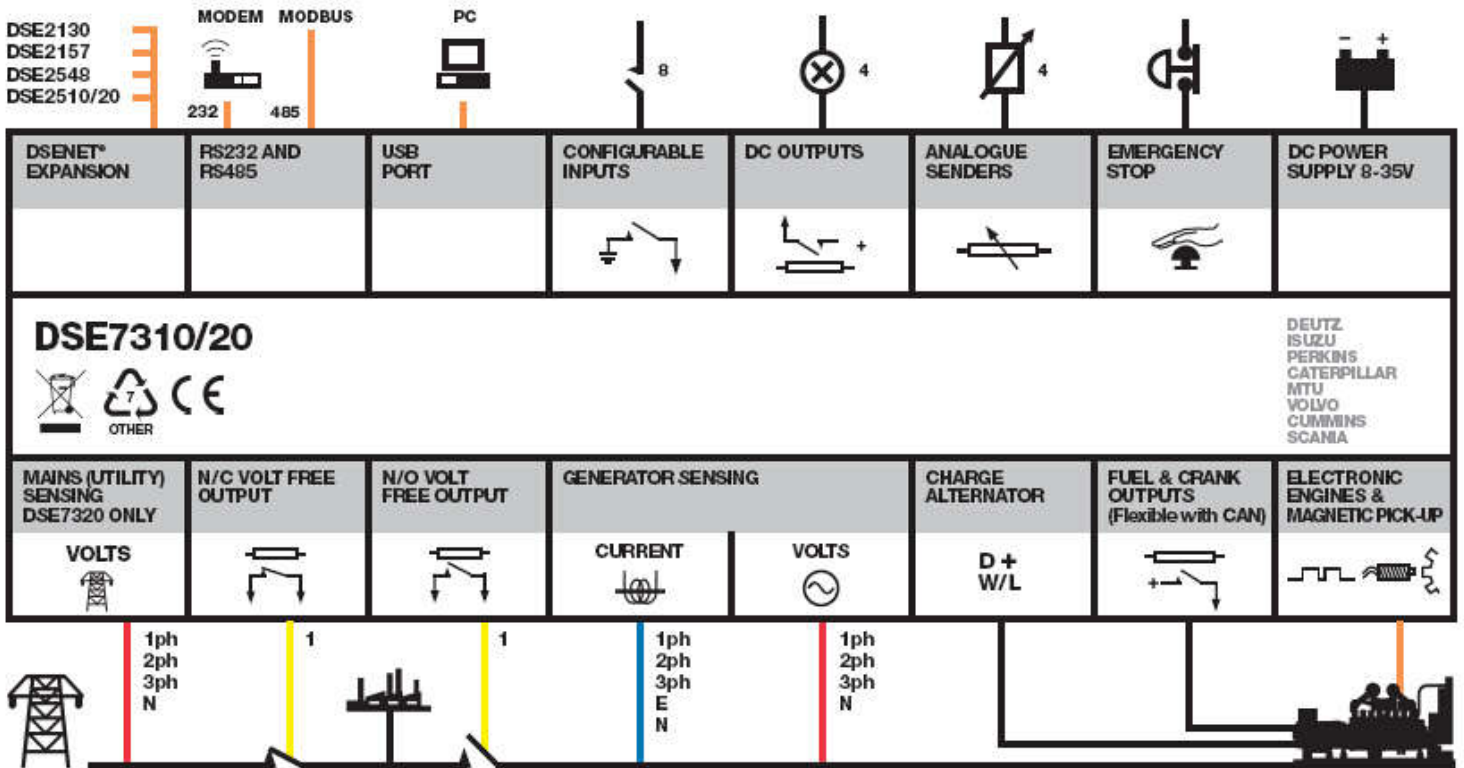

Overview dimension

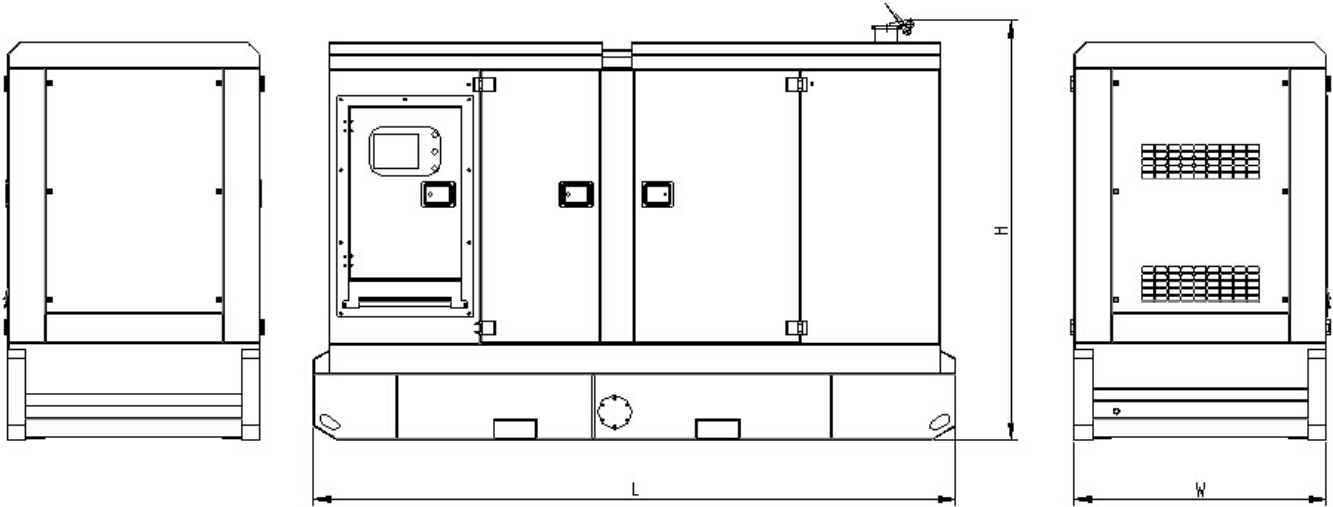

LSM650S3 (Silent type)

Configuration	L= Length (mm)	W= Width (mm)	H= High (mm)	Gross Weight (kg)
Enclosed set	5060	1912	2530	8100

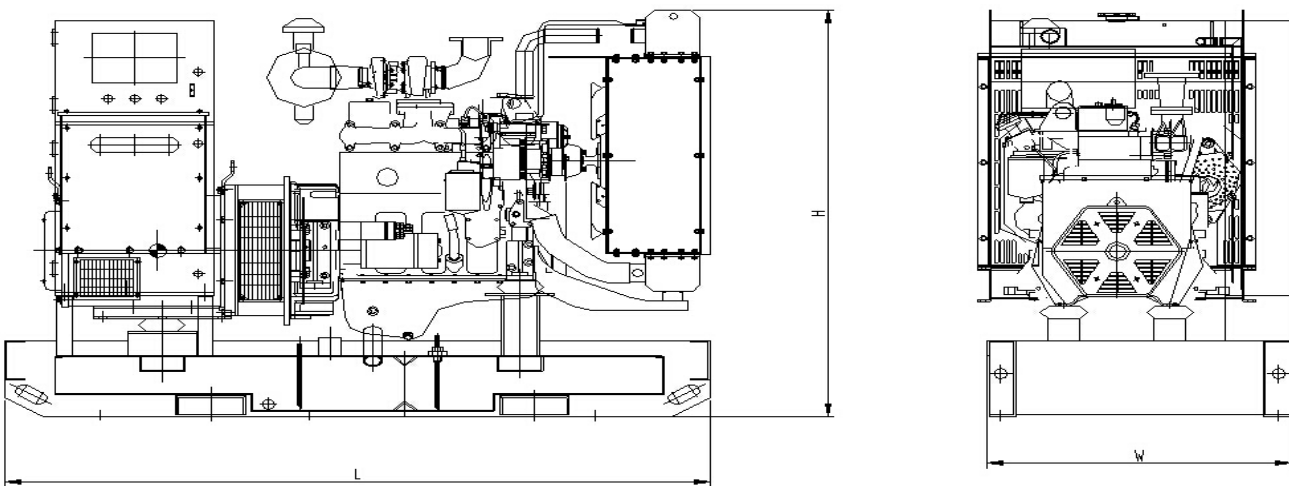

LSM650E3 (Open type)

Configuration	L= Length (mm)	W= Width (mm)	H= High (mm)	Gross Weight (kg)
Open set	4424	1756	2302	6000

Generating Sets Standard and Optional Features

Engine:

- 4-stroke, water-cooled diesel engine
- Standard air filter
- Standard fuel filter
- Standard oil filter
- Oil temperature sensor
- Low coolant level sensor
- 24V electrical system
- Radiator with blowing fan
- Industrial silence
- **Fuel water separator (optional)**
- **Water jacket heater (optional)**

Alternator:

- Class H insulation
- IP23 Protection
- Automatic Voltage Regulator (AVR)
- PMG excitation
- Single bearing alternator
- Stamford alternator

Electrical system:

- DSE 7320 control module
- Maintenance-free and anti-explosion battery
- Standard breaker
- **ABB breaker (optional)**

- **ATS (optional)**
- **Battery charger (optional)**
- **GMS monitoring (optional)**

Packing:

- Engine manual
- Alternator manual
- Gensets operation and maintenance manual
- Tool kit

Baseframe:

- Forklift pockets
- Pulling slots
- Earth wire protection
- Built-in anti vibration mountings
- Fuel outlet valve
- Standard 8 hours fuel tank
- **Enlarged 24 hours fuel tank (optional)**
- **Separated fuel tank (optional)**

Canopy:

- Weatherproof & sound-attened canopy
- Sound-absorbing material
- Lifting lug
- Emergency stop button
- Inside silencer

Contact your distributor / dealer for more information

WUXI LEES POWER COMPANY LIMITED

NO.312 Highway, Luoshe Town, Wuxi, China, 214000

Tel: 86-510-85166446

MP: 86-13771487360

Web: www.leespower.com

Email: lees@leespower.com

