



LSK12S3-6

Powered by KUBOTA



Diesel generator set



60HZ



Water-cooled



Three Phase



Super Silent 58 dBA/7m

Model	LSK12S3-6	
Standby Power	kVA	12.1
	kW	9.7
Prime Power	kVA	11.0
	kW	8.8
Frequency	Hz	60

LEES Kubota generators have a wide power range from 6~40kVA. The generators are widely used in industrial, commercial, backup, primary power source and outdoors project work and so on.

Kubota (Japan) enjoys a strong reputation in the global market for its excellent compact, lightweight, high-output engines. Kubota is the first company in the world to obtain certification for general-purpose engines under the California Air Resources Board (CARB) emissions regulations, Kubota's engines are renowned for their world-class environmental performance. Kubota is also acknowledged for its engineering capabilities in adapting engines to different applications.

Kubota Engine → Model: D1105-E2BG-CHN-1



KUBOTA Engine: D1105-E2BG-CHN-1	
Engine type	4 stroke, in line, water-cooled diesel engine
Number of cylinder	3
BorexStroke	78x78.4 mm
Combustion type	E-TVCS
Displacement	1.123 L
Horse power	11.5/1800 kW/rpm
Direction of rotation	Anticlockwise (face to flywheel)
Injection pump	Bosch type
Compression ratio	24.0
Governor type	All speed mechanical governor
Fuel oil	Diesel
Starting system	Electric starter
Lube oil capacity	5.1 L
Lube oil type	Above API CD class
Intake resistance	<1.96 kPa
Back pressure	<7.07 kPa
Combustion air requirement	0.88 m ³ /min
Exhaust gas volume	2.30 m ³ /min

MECC ALTE Alternator → Model: ECP28-2VS4A

Main features:

- 12 wire reconnectable stator/terminal arrangement
- Easy access for installation and maintenance
- 2/3 pitch winding as standard, to avoid excessive neutral currents
- Class H insulation with severe environmental protection as standard
- Built to conform with all leading industrial and marine standards
- 460 AVR as standard with 1.5% regulation and 2 phase sensing
- IP23 as standard

MECC ALTE Alternator: ECP28-2VS4A	
Pole No.	4
Connecting type	Three Phase four Wire
Protection grade	IP23
Exciter type	Brushless, self-exciting
Insulation class, Temperature rise	H/H

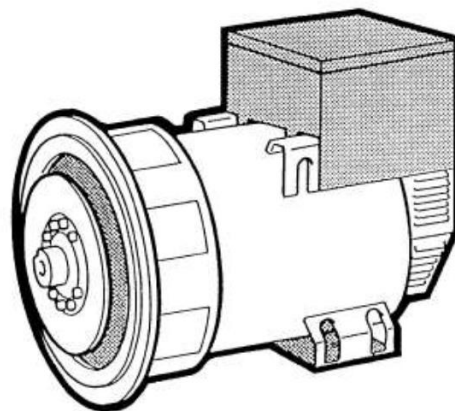

ECO
ECP



Deepsea control module → Model: 6020

The DSE6020 is an Auto Mains (Utility) Failure Control Module suitable for a wide variety of single, diesel or gas, gen-set applications.

Monitoring an extensive number of engine parameters, the modules will display warnings, shutdown and engine status information on the back-lit LCD screen, illuminated LEDs, remote PC and via SMS text alerts (with external modem).

The DSE6020 will also monitor the mains (utility) supply. The modules include USB, RS232 and RS485 ports as well as dedicated DSENet terminals for system expansion.



Key Features:

- 4-line back-lit LCD text display
- Five key menu navigation
- Front panel editing with PIN protection
- LED and LCD alarm indication
- Customisable status screens
- Power save mode
- Support for up to three remote display units
- 9 configurable inputs
- 8 configurable outputs
- Flexible sender inputs
- Configurable timers and alarms
- 3 configurable maintenance alarms
- Multiple date and time scheduler
- Configurable event log (250)
- Control logic facilities
- Easy access diagnostic page
- CAN and Magnetic Pick-up / Alt. Sensing
- Fuel usage monitor and low fuel alarms
- Charger alternator failure alarm
- Manual speed control
- Manual fuel pump control
- Engine exerciser
- "Protectons disabled" feature
- kW overload protection
- Power monitoring
- Load switching (load shedding and dummy load outputs)
- Automatic load transfer
- Unbalanced load protection
- Independent Earth Fault trip
- USB connectivity
- Backed up real time clock
- Fully configurable via DSE Configurable Suite PC software
- Configurable display languages
- Remote SCADA monitoring via DSE Configuration Suite PC software
- User selectable RS232 and RS485 communications
- SMS Messaging (additiional external modem required)
- Additional display screens to help with modem diagnostics
- DSENet expansion compatible
- Integral PLC editor

Overview dimension & Sound levels

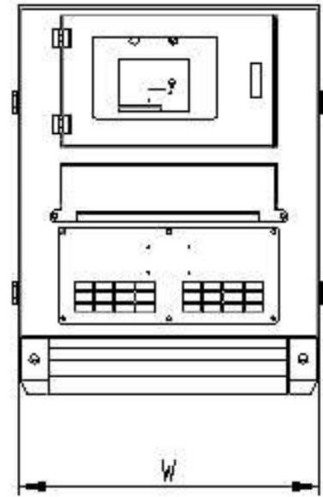
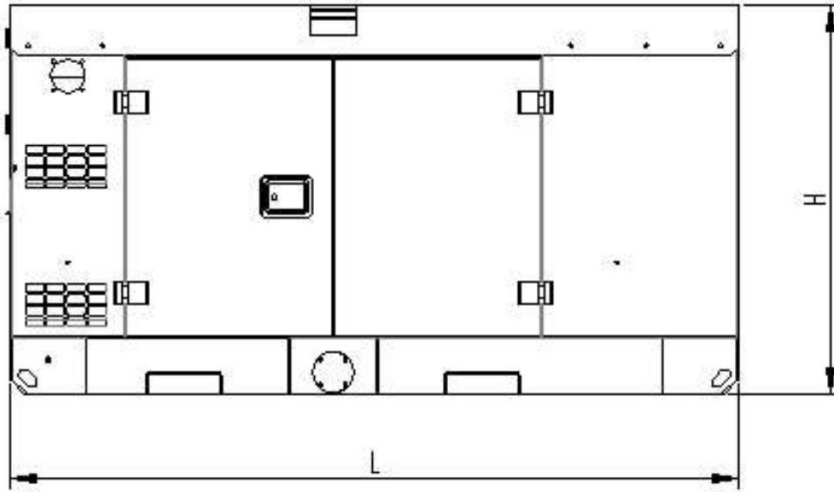

LSK12S3-6				
Configuration	L= Length (mm)	W= Width (mm)	H= High (mm)	Weight(kg)
Enclosed set	1680	800	1050	630

Generating Sets Standard and Optional Features

Engine:

- 4-stroke, water-cooled diesel engine
- Standard air filter
- Standard fuel filter
- Standard oil filter
- Oil temperature sensor
- Low coolant level sensor
- 24V electrical system
- Radiator with blowing fan
- Industrial silence
- **Fuel water separator (optional)**
- **Water jacket heater (optional)**

Alternator:

- Class H insulation
- IP23 Protection
- Automatic Voltage Regulator (AVR)
- Single bearing alternator
- **PMG excitation (optional)**

Electrical system:

- 6020 control module
- Maintenance-free and anti-explosion battery
- Standard breaker
- **7320 control module (optional)**
- **ATS (optional)**
- **Battery charger (optional)**
- **GMS monitoring (optional)**

Packing:

- Engine manual
- Alternator manual
- Gensets operation and maintenance manual
- Tool kit

Baseframe:

- Forklift pockets
- Pulling slots
- Earth wire protection
- Built-in anti vibration mountings
- Fuel outlet valve
- Standard 8 hours fuel tank
- **Separated fuel tank (optional)**

Canopy:

- Weatherproof & sound-attenuated canopy
- Sound-absorbing material
- Lifting lug
- Emergency stop button
- Inside silencer
- **Trailer (optional)**

Contact your distributor / dealer for more information

WUXI LEES POWER COMPANY LIMITED

NO.312 Highway, Luoshe Town, Wuxi, China, 214000

Tel: 86-510-85168446

MP: 86-13771487360

Web: www.leespower.com

Email: sales@leespower.com

