



LSDS310S3

Powered by Doosan



50HZ



Water-cooled



Three Phase



Diesel

Model	LSDS310S3	
Standby Power	kVA	310
	kw	246
Prime Power	kVA	272
	kw	218
Frequency	Hz	50
Voltage	V	230/400
Rated speed	rpm	1500
Fuel Consumption 100% Load	L/Hr	63.1
Fuel Consumption 75% Load	L/Hr	47
Fuel Consumption 50% Load	L/Hr	31.3

LEES Doosan generators have a wide power range from 310~828kVA. The generators are widely used in industrial, commercial, backup, primary power source and outdoors project work and so on.

DOOSAN Group founded in 1896 is one of the largest consortium in Korean currently. Doosan Engine is established after the acquisition of Daewoo Integrated Machinery Co., Ltd in 2005, named Doosan Engineering Machinery, and continue to develop and launch a new generation product with first class and reliable performance base on the original Daewoo engine.

Doosan engine → Model: P126T



Doosan Engine: P126TI	
Air intake system	Turbo, Air/Air Cooling
Fuel system	BOSCH P type pump
Cylinder arrangement	6 in line
Displacement	11.051L
BorexStroke	123x155mm
Compression ratio	17:0
Rated RPM	1500
Max. standby power at rated RPM	294kW
Governor type	Electronic
Exhaust gas flow	47.4m ³ /min
Exhaust temperature	590°C
Max. back pressure	6kPa
Max. intake restriction	6.35kPa
Intake air flow	20.1m ³ /min
Cooling fan air flow	607m ³ /min
Total oil capacity	25L
Oil consumption	<4g/kw.h
Engine Oil Tank Capacity	23L
Oil Pressure at Rated RPM	345-483kPa
Total coolant capacity	60L
Thermostat	71-85°C
Max. water temperature	103°C

Alternator

Main features:

- 12 wire reconnectable stator/terminal arrangement
- Easy access for installation and maintenance
- 2/3 pitch winding as standard, to avoid excessive neutral currents
- Class H insulation with severe environmental protection as standard
- Built to conform with all leading industrial and marine standards
- 460 AVR as standard with 1.5% regulation and 2 phase sensing
- IP23 as standard

Alternator specifications	
Number of phase	3
Connecting type	3 Phase 4 Wire, "Y" type connecting
Number of bearing	1
Power Factor	0.8
Protection grade	IP23
Altitude	≤1000m
Exciter type	Brushless, self-exciting
Insulation class, Temperature rise	H/H
Telephone Influence Factor (TIF)	<50
THF	<2%
Voltage Regulation, Steady state	±1%
Alternator capacity	300kVA
Alternator efficiencies	93%
Air cooling flow	0.99m ³ /s

Alternator options	
Stamford	S4L1D-D41
Leroy Somer	TAL046F
Lees	LA 4D





Deepsea control module → Model: 7320

The DSE7320 is an Auto Mains (Utility) Failure Control Module suitable for a wide variety of single, diesel or gas, gen-set applications.

Monitoring an extensive number of engine parameters, the modules will display warnings, shutdown and engine status information on the back-lit LCD screen, illuminated LEDs, remote PC and via SMS text alerts (with external modem).

The DSE7320 will also monitor the mains (utility) supply. The modules include USB, RS232 and RS485 ports as well as dedicated DSENet terminals for system expansion.



Key Features:

- 4-line back-lit LCD text display
- Five key menu navigation
- Front panel editing with PIN protection
- LED and LCD alarm indication
- Customisable status screens
- Power save mode
- Support for up to three remote display units
- 9 configurable inputs
- 8 configurable outputs
- Flexible sender inputs
- Configurable timers and alarms
- 3 configurable maintenance alarms
- Multiple date and time scheduler
- Configurable event log (250)
- Control logic facilities
- Easy access diagnostic page
- CAN and Magnetic Pick-up / Alt. Sensing
- Fuel usage monitor and low fuel alarms
- Charger alternator failure alarm
- Manual speed control
- Manual fuel pump control
- Engine exerciser
- “Protectons disabled” feature
- kW overload protection
- Power monitoring
- Load switching (load shedding and dummy load outputs)
- Automatic load transfer
- Unbalanced load protection
- Independent Earth Fault trip
- USB connectivity
- Backed up real time clock
- Fully configurable via DSE Configurable Suite PC software
- Configurable display languages
- Remote SCADA monitoring via DSE Configuration Suite PC software
- User selectable RS232 and RS485 communications
- SMS Messaging (additiional external modem required)
- Additional display screens to help with modem diagnostics
- DSENet expansion compatible
- Integral PLC editor

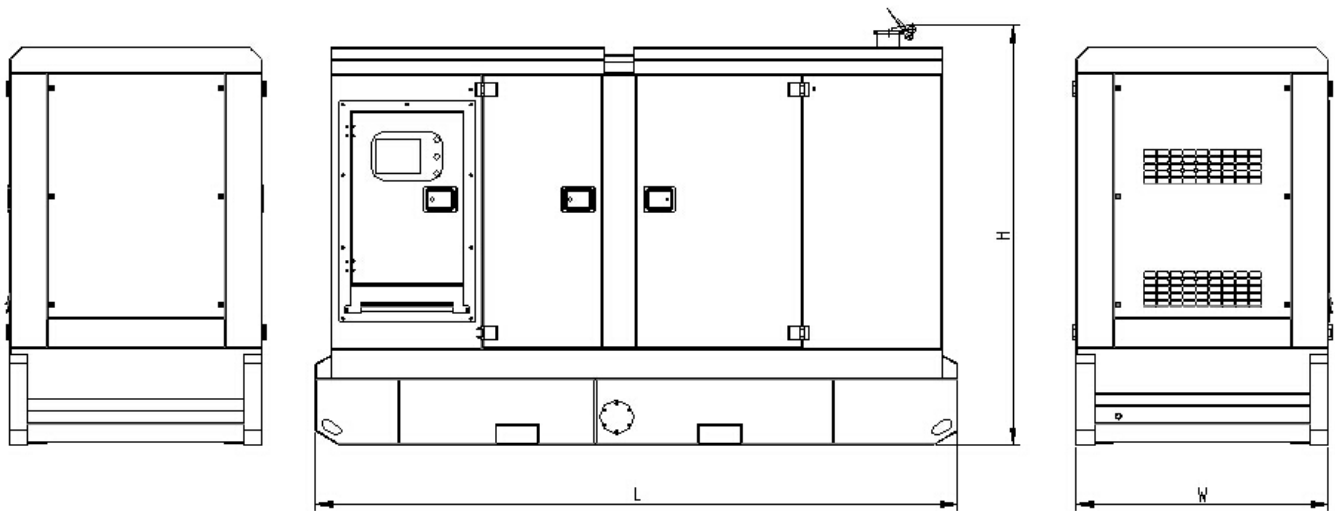

LSDS310S3 (Silent type)

Configuration	L= Length (mm)	W= Width (mm)	H= High (mm)	Gross Weight (kg)
Enclosed set	4260	1462	2100	2880

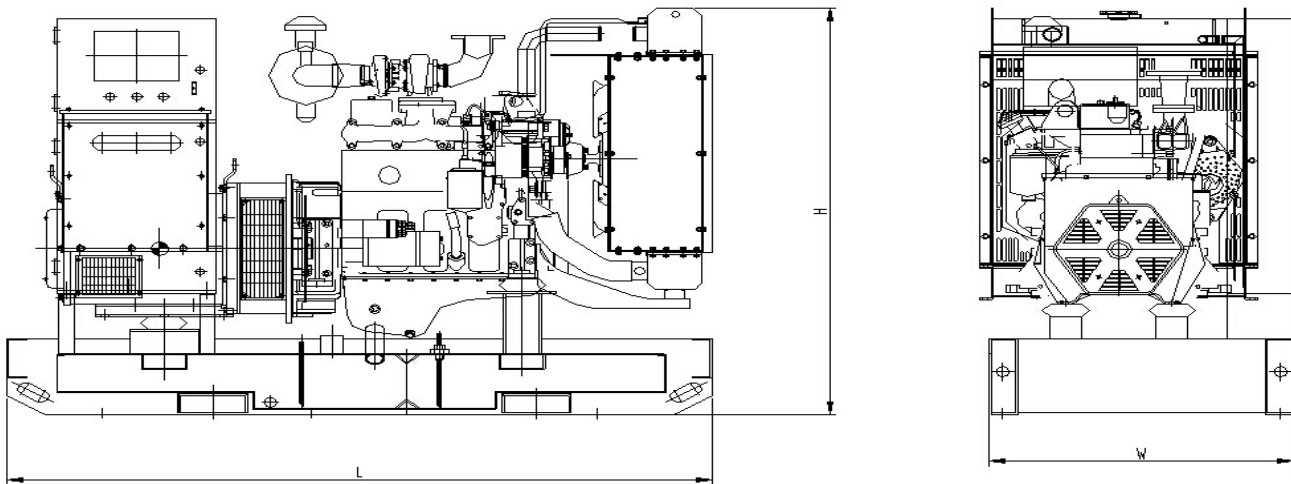

LSDS310E3 (Open type)

Configuration	L= Length (mm)	W= Width (mm)	H= High (mm)	Gross Weight (kg)
Open set	3365	1612	2000	2220

Generating Sets Standard and Optional Features

Engine:

- 4-stroke, water-cooled diesel engine
- Standard air filter
- Standard fuel filter
- Standard oil filter
- Oil temperature sensor
- Low coolant level sensor
- 24V electrical system
- Radiator with blowing fan
- Industrial silence
- **Fuel water separator (optional)**
- **Water jacket heater (optional)**

Alternator:

- Class H insulation
- IP23 Protection
- Automatic Voltage Regulator (AVR)
- PMG excitation
- Single bearing alternator
- Stamford alternator

Electrical system:

- DSE 7320 control module
- Maintenance-free and anti-explosion battery
- Standard breaker
- **ABB breaker (optional)**
- **ATS (optional)**

- **Battery charger (optional)**
- **GMS monitoring (optional)**

Packing:

- Engine manual
- Alternator manual
- Gensets operation and maintenance manual
- Tool kit

Baseframe:

- Forklift pockets
- Pulling slots
- Earth wire protection
- Built-in anti vibration mountings
- Fuel outlet valve
- Standard 8 hours fuel tank
- **Enlarged 24 hours fuel tank (optional)**
- **Separated fuel tank (optional)**

Canopy:

- Weatherproof & sound-attenuated canopy
- Sound-absorbing material
- Lifting lug
- Emergency stop button
- Inside silencer
- **Trailer generator (optional)**

Contact your distributor / dealer for more information

WUXI LEES POWER COMPANY LIMITED

NO.312 Highway, Luoshe Town, Wuxi, China, 214000

Tel: 86-510-85168446

MP: 86-13771487360

Web: www.leespower.com

Email: sales@leespower.com

