

## LSSM825E3

Powered by Mitsubishi



50 Hz 50HZ

Water-cooled

Three Phase

Diesel

Model	LSSM825E3	
Standby Power	kVA	825
	kw	660
Prime Power	kVA	750
	kw	600
Frequency	Hz	50
Voltage	V	230/400
Rated speed	rpm	1500
Fuel Consumption 100% Load	g/kw.h	206
Fuel Consumption 75% Load	g/kw.h	-
Fuel Consumption 50% Load	g/kw.h	-

LEES Mitsubishi generators have a wide power range from 750~2500kVA. The generators are widely used in industrial, commercial, backup, primary power source and outdoors project work and so on.

Shanghai Mitsubishi heavy engine co., LTD. is a joint venture between Japan's Mitsubishi heavy industry co., LTD and Shanghai diesel engine co., LTD. The company mainly produce Mitsubishi heavy industries of large and medium-sized engine and the every technology, production, and quality standard is synchronize with Mitsubishi Japan heavy industries.

Lees cooperate with Mitsubishi (Shanghai), manufacturing LSSM series diesel generating sets, with its excellent quality and price, Lees Mitsubishi Generator sold vastly overseas. This series of diesel engines meet with U.S. EPA2 emissions standard of diesel engine power station.

**Mitsubishi engine → Model: S6R2-PTAA-C**

<b>Mitsubishi Engine: S6R2-PTAA-C</b>	
<b>Air intake system</b>	Turbocharged, Water/Air Cooling
<b>Fuel system</b>	MITSUBISHI PS6
<b>Cylinder arrangement</b>	6 in line
<b>Displacement</b>	29.96L
<b>BorexStroke</b>	170x220mm
<b>Compression ratio</b>	14.1
<b>Rated RPM</b>	1500
<b>Max. standby power at rated RPM</b>	710kW/952HP
<b>Governor type</b>	Electronic
<b>Exhaust gas flow</b>	159m <sup>3</sup> /min
<b>Exhaust temperature</b>	520°C
<b>Max. back pressure</b>	5.8kPa
<b>Max. intake restriction</b>	6.1kPa
<b>Burning capacity</b>	60m <sup>3</sup> /min
<b>Air flow</b>	726m <sup>3</sup> /min
<b>Total oil capacity</b>	94L
<b>Oil consumption</b>	≤4g/kw.h
<b>Engine Oil Tank Capacity</b>	71-85L
<b>Oil Pressure at Rated RPM</b>	490-640kPa
<b>Total coolant capacity</b>	258L
<b>Thermostat</b>	71-85°C
<b>Max. water temperature</b>	98°C

## Alternator

Main features:

- 12 wire reconnectable stator/terminal arrangement
- Easy access for installation and maintenance
- 2/3 pitch winding as standard, to avoid excessive neutral currents
- Class H insulation with severe environmental protection as standard
- Built to conform with all leading industrial and marine standards
- 460 AVR as standard with 1.5% regulation and 2 phase sensing
- IP23 as standard

Alternator specifications	
Number of phase	3
Connecting type	3 Phase 4 Wire, "Y" type connecting
Number of bearing	1
Power Factor	0.8
Protection grade	IP23
Altitude	≤1000m
Exciter type	Brushless, self-exciting
Insulation class, Temperature rise	H/H
Telephone Influence Factor (TIF)	<50
THF	<2%
Voltage Regulation, Steady state	±1%
Alternator capacity	750kVA
Alternator efficiencies	93.3%
Air cooling flow	1.295m <sup>3</sup> /s

Alternator options	
Stamford	S6L1D-C41
Leroy Somer	TAL A49 C
Lees	LA6B

**Deepsea control module → Model: 7320**



The DSE7320 is an Auto Mains (Utility) Failure Control Module suitable for a wide variety of diesel or gas genset applications.

Monitoring an extensive number of engine parameters, the modules will display warnings, shutdown and engine status information on the back-lit LCD screen, illuminated LEDs, remote PC and via SMS test alerts (with external modem).

The DSE7320 will also monitor the mains (utility) supply. The modules include USB, RS232 and RS485 ports as well as dedicated DSENet terminals for system expansion.



**Key Features:**

- 4-line back-lit LCD text display
- Five key menu navigation
- Front panel editing with PIN protection
- LED and LCD alarm indication
- Customisable status screens
- Power save mode
- Support for up to three remote display units
- 9 configurable inputs
- 8 configurable outputs
- Flexible sender inputs
- Configurable timers and alarms
- 3 configurable maintenance alarms
- Multiple date and time scheduler
- Configurable event log (250)
- Control logic facilities
- Easy access diagnostic page
- CAN and Magnetic Pick-up / Alt. Sensing
- Fuel usage monitor and low fuel alarms
- Charger alternator failure alarm
- Manual speed control
- Manual fuel pump control
- Engine exerciser
- "Protectons disabled" feature
- kW overload protection
- Power monitoring
- Load switching (load shedding and dummy load outputs)
- Automatic load transfer
- Unbalanced load protection
- Independent Earth Fault trip
- USB connectivity
- Backed up real time clock
- Fully configurable via DSE Configurable Suite PC software
- Configurable display languages
- Remote SCADA monitoring via DSE Configuration Suite PC software
- User selectable RS232 and RS485 communications
- SMS Messaging (additiional external modem required)
- Additional display screens to help with modem diagnostics
- DSENet expansion compatible
- Integral PLC editor

Deepsea control module → Model: 7320

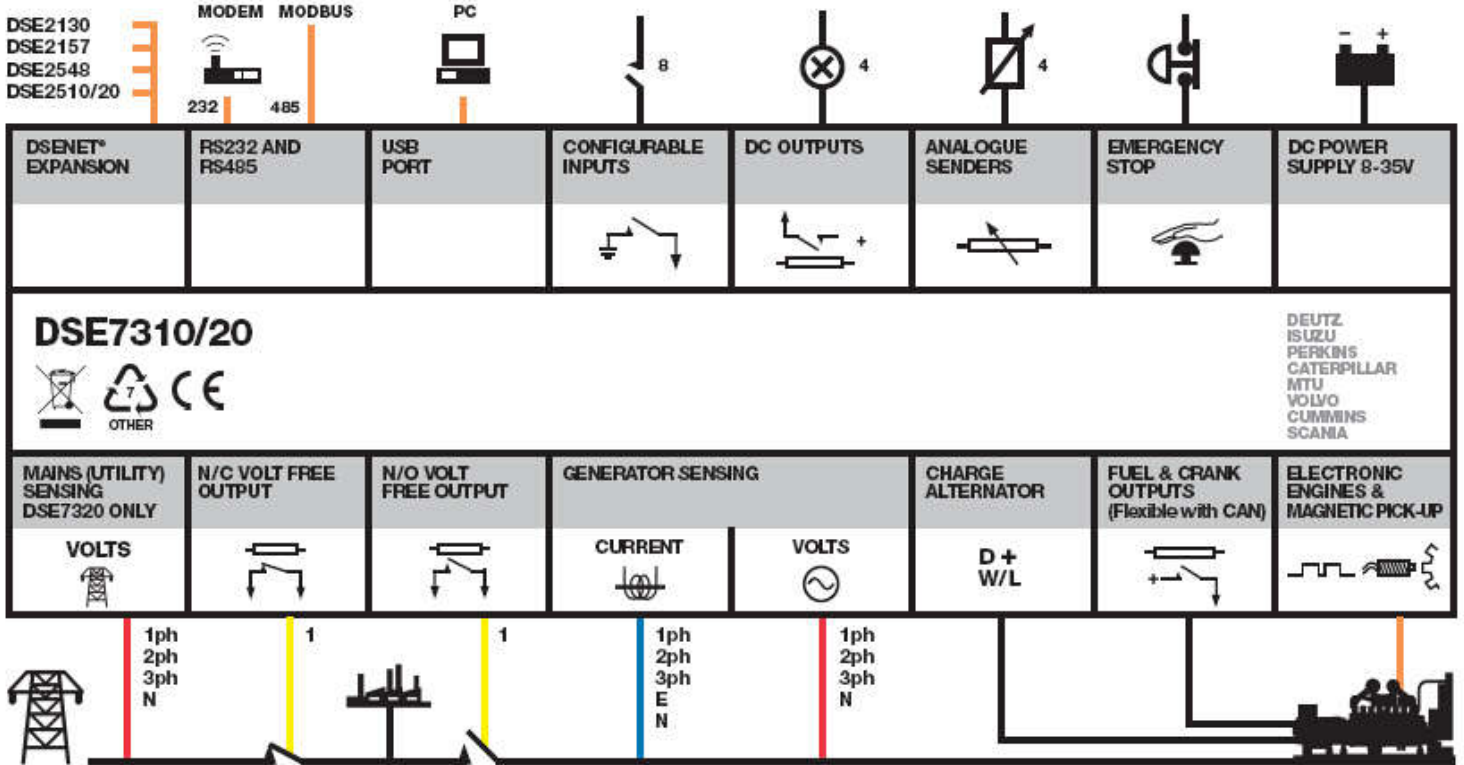

**Overview dimension**

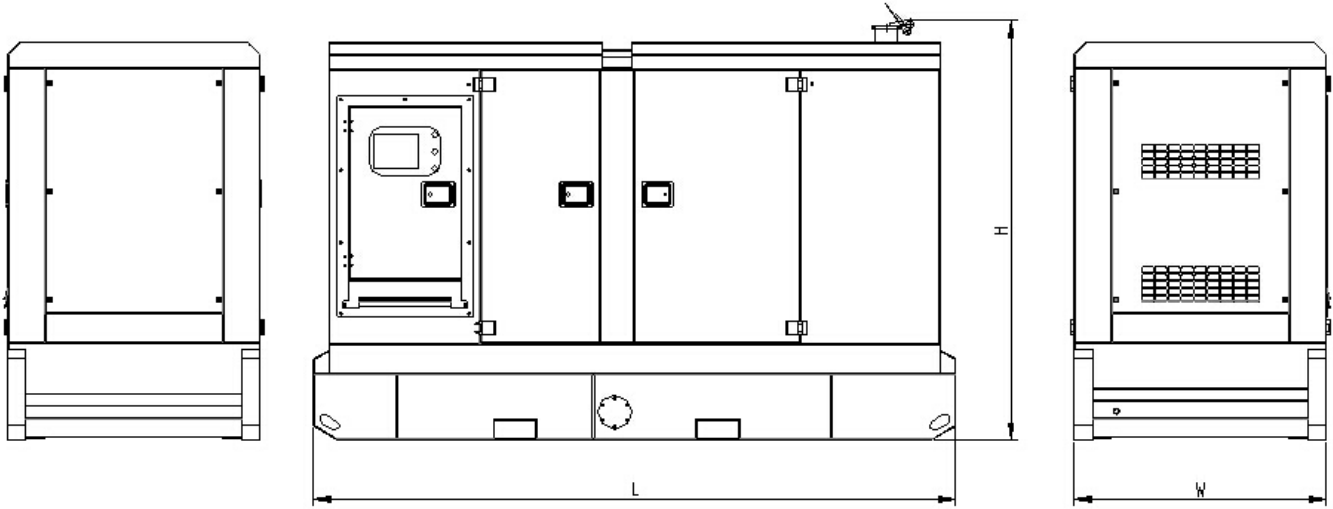

**LSSM825S3 (Silent type)**

Configuration	L= Length (mm)	W= Width (mm)	H= High (mm)	Gross Weight (kg)
Enclosed set	5806	2260	2554	7100

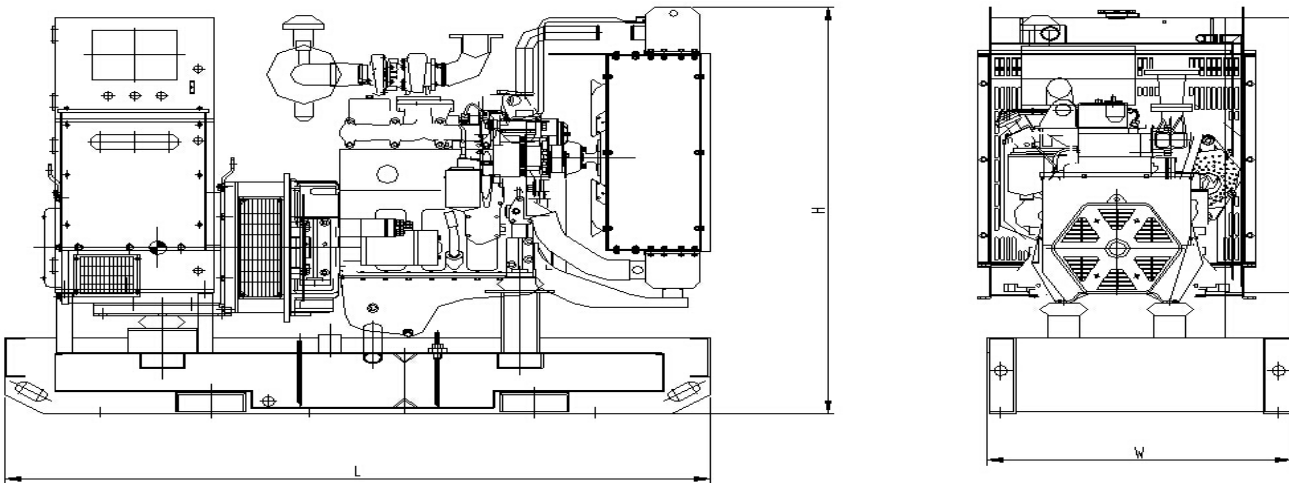

**LSSM825E3 (Open type)**

Configuration	L= Length (mm)	W= Width (mm)	H= High (mm)	Gross Weight (kg)
Open set	3965	1710	2200	5200

## Generating Sets Standard and Optional Features

### Engine:

- 4-stroke, water-cooled diesel engine
- Standard air filter
- Standard fuel filter
- Standard oil filter
- Oil temperature sensor
- Low coolant level sensor
- 24V electrical system
- Radiator with blowing fan
- Industrial silence
- **Fuel water separator (optional)**
- **Water jacket heater (optional)**

### Alternator:

- Class H insulation
- IP23 Protection
- Automatic Voltage Regulator (AVR)
- PMG excitation
- Single bearing alternator
- Stamford alternator

### Electrical system:

- DSE 7320 control module
- Maintenance-free and anti-explosion battery
- Standard breaker
- **ABB breaker (optional)**
- **ATS (optional)**

- **Battery charger (optional)**
- **GMS monitoring (optional)**

### Packing:

- Engine manual
- Alternator manual
- Gensets operation and maintenance manual
- Tool kit

### Baseframe:

- Forklift pockets
- Pulling slots
- Earth wire protection
- Built-in anti vibration mountings
- Fuel outlet valve
- Standard 8 hours fuel tank
- **Enlarged 24 hours fuel tank (optional)**
- **Separated fuel tank (optional)**

### Canopy:

- Weatherproof & sound-attenuated canopy
- Sound-absorbing material
- Lifting lug
- Emergency stop button
- Inside silencer

## Contact your distributor / dealer for more information

### WUXI LEES POWER COMPANY LIMITED

NO.312 Highway, Luoshe Town, Wuxi, China, 214000

Tel: 86-510-85168446

MP: 86-13771487360

Web: [www.leespower.com](http://www.leespower.com)

Email: [sales@leespower.com](mailto:sales@leespower.com)

